

Vocera Voice Server Installation Guide

Version 5.2.3



Notice

Copyright © 2002-2019 Vocera Communications, Inc. All rights reserved.

Vocera® is a registered trademark of Vocera Communications, Inc.

This software is licensed, not sold, by Vocera Communications, Inc. ("Vocera"). The reference text of the license governing this software can be found at <http://www.vocera.com/legal/>. The version legally binding on you (which includes limitations of warranty, limitations of remedy and liability, and other provisions) is as agreed between Vocera and the reseller from whom your system was acquired and is available from that reseller.

Certain portions of Vocera's product are derived from software licensed by the third parties as described at <http://www.vocera.com/legal/>.

Microsoft®, Windows®, Windows Server®, Internet Explorer®, Excel®, and Active Directory® are registered trademarks of Microsoft Corporation in the United States and other countries.

Java® is a registered trademark of Oracle Corporation and/or its affiliates.

All other trademarks, service marks, registered trademarks, or registered service marks are the property of their respective owner/s. All other brands and/or product names are the trademarks (or registered trademarks) and property of their respective owner/s.

Vocera Communications, Inc.

www.vocera.com

tel :: +1 408 882 5100

fax :: +1 408 882 5101

Last modified: 2019-06-19 11:24

Docs_VS_523Rel build 177



Contents

Introduction	7
About This Guide	8
About the Vocera Voice Server System Software	9
Software Utilities for Badge Configuration.....	9
Specialized Modules.....	9
Optional Software Components.....	10
Vocera Technical Support Tools and Software Utilities.....	10
Electronic Software Distribution	12
System Requirements	13
Server Requirements	14
Vocera Voice Server Requirements.....	14
Vocera SIP Telephony Gateway Requirements.....	14
Cisco Unified Communications Manager Support.....	15
Dialogic Media Gateway Support.....	15
Vocera Client Gateway Requirements.....	15
Vocera Report Server Limitations.....	16
Infrastructure Requirements	17
Configuration Hardware Requirements	18
Browser Requirements	19
Browser Recommendations and Requirements.....	19
Upgrading an Existing Installation	21
Before Upgrading	22
Upgrade Considerations for a Standalone Environment.....	22
Upgrade Consideration for a Cluster: Planned Downtime.....	23
Active and Inactive Node Order.....	23
Upgrade Considerations for the Report Server.....	23
Upgrading Vocera Voice Server to Version 5.2.3	25
Vocera Voice Server Upgrade Paths.....	25
Upgrading a Standalone Vocera Voice Server.....	25
Upgrading a Vocera Voice Server Cluster.....	26
Upgrading Vocera Voice Server on a New Server.....	28
Upgrading Properties Files.....	29
Backing up Vocera Data.....	30
Upgrading Vocera Voice Server Components	31
Upgrading Vocera Staff Assignment.....	31

Standard and Premier.....	31
Upgrading Vocera SIP Telephony Gateway.....	31
Upgrading Vocera Client Gateway.....	32
Upgrading Vocera Report Server.....	32
Upgrading Vocera Administration Interface Applications.....	33
Changes in Behavior.....	35
Suggested Post-Upgrade Tasks.....	37
Installing on a New Server.....	38
Preparing for a New Installation.....	39
Preparing the Vocera Voice Server.....	39
Vocera SIP Telephony Gateway Architecture.....	39
Enabling Windows Installer.....	40
Removing the Windows DHCP Server.....	40
Configuring Windows Update.....	40
Configuring Performance Options.....	40
Synchronizing Cluster Server Clocks.....	41
Preparing the Vocera SIP Telephony Gateway.....	41
About Vocera SIP Telephony Gateway.....	41
Vocera SIP Telephony Software Benefits.....	41
Vocera SIP Telephony Gateway Architecture.....	42
Session Initiation Protocol Support.....	43
Outgoing Calls.....	43
Incoming Calls.....	43
Using the SIP Testing Tool.....	44
Vocera SIP Telephony Gateway License Requirements.....	44
Telephony SIP Deployment Scenarios.....	44
Telephony High Availability.....	49
Vocera SIP Telephony Gateway and PBX Failover Support.....	49
Checklist for Preparing the Vocera SIP Telephony Gateway.....	49
Preparing the Vocera Client Gateway.....	50
Vocera Client Gateway Architecture.....	50
Location Service.....	50
Vocera Client Gateway Deployment Scenarios.....	51
Checklist for Preparing the Vocera Client Gateway.....	54
Preparing the Vocera Report Server.....	55
Preparing the Vocera Voice Server.....	55
Preparing the Report Server.....	55
Installing Vocera Voice Server Software.....	56
Running the Vocera Voice Installation Program.....	56
Installing Vocera Voice Server Software Components.....	61
Running the Vocera Client Gateway Installation Program.....	61
Running the Vocera Report Server Installation Program.....	64
Running the Vocera SIP Telephony Gateway Installation Program.....	68
Uninstalling Vocera Voice Server Software.....	72

Post-Installation Configuration	73
Setting Up a Staging Server	74
Staging Server Network Architecture.....	74
Configuring Badges to Connect to the Staging Server.....	75
Setting Up a Vocera Cluster	77
About Vocera Voice Server Clusters.....	77
Setting Up an Initial Cluster Configuration.....	79
Controlling a Cluster.....	81
Forcing a Failover.....	82
Restarting a Standby Node.....	82
Managing Cluster Nodes.....	82
Starting a Standalone Server.....	82
Rejoining a Standalone Server to a Cluster.....	83
Breaking Up a Cluster.....	83
Manually Installing the Vocera License File	84
Manually Installing the Vocera License for a Cluster Environment.....	84
Setting Up Users and Groups	86
Completing the Configuration.....	86
Testing the Configuration.....	87
Appendixes	89
Using the Vocera Control Panel	90
Vocera System Tray Icon.....	90
Displaying Vocera Control Panel Help.....	91
Vocera Control Panel Menus.....	91
Determining the Status of the Server.....	91
Stopping and Restarting the Server.....	92
Controlling the Display of Events.....	92
Using the Cluster Menu.....	93
Changing the Vocera Voice Server IP Address.....	93
Shutting Down the Vocera Voice Server Server.....	94
Vocera Cluster Upgrade Checklist	95
IP Port Usage	97
Engage IP Ports	98
Changing the IP Address of the Vocera Voice Server	103
Introducing the Change Server IP Address Utility.....	103
Supported Vocera Environments.....	103
Using the Change Server IP Address Utility.....	103
Vocera Localization Suite	105
Dialing Plan.....	105
Genie Personas.....	105
Grammars.....	105
Localization Packs.....	106
Performance Tuning for Large Customers	107

Installation Prerequisites and Recommendations.....	107
Post-Installation Recommendations.....	107
Configuring Performance Options.....	108

Introduction

Learn about Vocera software, products and utilities, and basic information related to using this guide.

Vocera Communication enables hands-free, voice-controlled wireless voice communication using the wearable Vocera badge throughout a wireless networked building or campus. For an end user, communication is as easy as pushing a button on the badge and saying, “Call Jodie Lee.”

This guide describes how to install or upgrade a Vocera Voice Communication system. Setting up the system entails installing server software, configuring Vocera badges, and initializing the Vocera Voice Server database with the names of users and groups. If telephony integration is required, you can install Vocera SIP Telephony Gateway. Other optional components, such as Vocera Client Gateway, a gateway for smartphones running the Vocera Collaboration Suite application, and Vocera Report Server, can also be installed.

- [About This Guide](#) on page 8
- [About the Vocera Voice Server System Software](#) on page 9
- [Electronic Software Distribution](#) on page 12



About This Guide

Learn how to use this guide and more about its contents and organization.

This guide provides installation instructions for Vocera Voice Server software components. Its purpose is to help you install the software successfully.

The information in this guide is organized into the following parts:

- **System Requirements** on page 13 describes system requirements.
- **Upgrading an Existing Installation** on page 21 describes how to upgrade your Vocera Voice Server system to Version 5.2.3.
- **Preparing for a New Installation** on page 39 describes how to prepare a server before installing Vocera Voice Server software.
- **Installing Vocera Voice Server Software** on page 56 describes how to install Vocera Voice Server software.
- **Installing Vocera Voice Server Software Components** on page 61 describes how to install the Vocera SIP Telephony Gateway, Vocera Client Gateway, and Report Server Software with your Vocera Voice Server.
- **Post-Installation Configuration** on page 73 describes additional Vocera Voice Server setup tasks.
- **Appendixes** on page 89 provide additional information about installing and configuring Vocera Voice Server.

After you install Vocera successfully, you need to configure and administer the system.

For Vocera Voice Server administration and Vocera badge configuration instructions, refer to the following Vocera guides:

- *Vocera Voice Server Administration Console Guide*
- *Vocera Device Configuration Guide*

For information about the Vocera Collaboration Suite and using other client devices in the Vocera environment, refer to the following Vocera guides:

- *Vocera Collaboration Suite Apple iOS User Guide*
- *Vocera Collaboration Suite Android User Guide*



About the Vocera Voice Server System Software

Learn the main components of Vocera Voice Server System Software.

The Vocera Voice Server system software includes the following main components:

- **Vocera Voice Server Program**—provides the central system functionality, and calls on the other components for specific services.
- **Embedded MySQL Database™** —stores user profiles (which contain personal information and badge settings), group and location information, and system settings.
- **Nuance™ Speech Recognition, Verifier, and Vocalizer™ Software** —provides the speech recognition, and text-to-speech engines used by the Vocera Voice Server interface.
- **Apache / Tomcat Web Server**—hosts the browser-based Administration Console and User Console applications.

Software Utilities for Badge Configuration

Review a brief description for the Badge Properties Editor and Badge Configuration Utility.

The Vocera system software includes the following utilities:

- **Badge Properties Editor**—lets you set values for badge properties so the Vocera badges can connect to the wireless network. See the *Vocera Device Configuration Guide*.
- **Badge Configuration Utility**—downloads the properties you set with the Badge Properties Editor, as well as any firmware upgrades, to your badges. See the *Vocera Device Configuration Guide*.

Specialized Modules

Learn about the modules provided for working with Vocera Voice Server system software.

The Vocera Voice Server system software includes the following specialized modules:

- The **Vocera System Tray Icon** appears in the server notification area at the right of the taskbar on the Vocera Voice Server, Vocera SIP Telephony Gateway, and Vocera Client Gateway. The Vocera system tray icon changes to indicate the current running state of the Vocera system. The system tray provides access to the Vocera Control Panel, which lets you control the server.
- The **Vocera launcher** is a Windows service that starts automatically when the computer boots. The launcher starts the Vocera Voice Server and the associated services it requires, such as the MySQL, Nuance, and Apache/Tomcat components, as well as the optional Vocera Telephony Solution Software, if installed.
- **Administration Console**, a browser-based application, provides the interface to the Vocera Voice Server. See the *Vocera Voice Server Administration Console Guide* or the Administration Console's online help for an overview.

- **User Console**, also a browser-based application, allows individual users to set their own badge preferences and maintain their own contact information. See the *Vocera Voice Server Administration Console Guide* for information about logging in and granting access. See the *Vocera Voice Server User Console Guide* for detailed information.

Optional Software Components

Learn about the other products that you can implement with Vocera Voice Server.

Vocera also offers the following optional software components:

- **Vocera SIP Telephony Gateway** integrates the Vocera Voice Server with your telephone system, allowing badges and telephones to communicate seamlessly. The telephony software provides a Session Initiation Protocol (SIP) telephony gateway between the Vocera Voice Server and an IP PBX or a Voice over Internet Protocol (VoIP) gateway. Vocera SIP Telephony Gateway supports non-SIP enabled PBXs via Dialogic Media Gateway or other SIP/TDM gateway products.
- **Vocera Client Gateway** supports client devices and smartphones and Vocera Collaboration Suite clients, providing a signaling and multimedia gateway from the phones to the Vocera Voice Server for all calls.
- **Report Server Software** uses log files generated by the Vocera Voice Server to create an extensive set of reports. Some reports can help you spot usage trends, keep track of badges, and monitor call volume. Other reports help you diagnose end-user and network issues related to the Vocera system.
- **Vocera Messaging Interface** Vocera Messaging Interface enables two-way messaging between the Vocera Communications System and third-party applications, such as nurse call systems, patient monitoring systems, supply management systems, point of sale and other store management applications, network management software, HVAC, industrial alarms and other enterprise applications. The Vocera Messaging Interface supersedes the nurse call interface offered with earlier versions of Vocera.
- **Vocera Administration Interface** is a Java API that enables you to control and administer the Vocera system programmatically.

Vocera Technical Support Tools and Software Utilities

Learn how to work with Vocera Technical Support tools and utilities.

When you install the Vocera Voice Server, the installation program also installs tools and utilities that can be used to facilitate the exchange of Vocera Voice Server information with Vocera Technical Support and to aid in troubleshooting. These tools provide the best way to send server logs and other debugging data and tasks you can use when working with Vocera Technical Support.

The utilities below are launched from the Windows Start menu:

- **Change Server IP Address**—The Vocera SIP Telephony Gateway, and Vocera Client Gateway need to know the IP address(es) of the Vocera Voice Server. You enter this IP address(es) when you install the software but you can also launch the utility and change the IP address as needed.
- **Enable Dual Recognition Server** —Allows you to enable and disable Dual Speech Recognition in order to improve speech recognition. You can enable a second recognition server when you install the software. In addition and after installation, you can launch the utility and change the setting as desired.
- **Update SSL and Connector Settings** —Enabling SSL on the Vocera Voice Server affects how Vocera Messaging Platform and clients connect to the server. You can enable SSL when you install the software. In addition and after installation, you can launch the utility and change the setting as desired.

For more information about more available support tools, see the **readme.txt** file located in the **\vocera\support** folder on your Vocera Voice Server, and contact Vocera Technical Support.



Electronic Software Distribution

Learn how to download Vocera Voice Server software.

Vocera provides software delivery through an electronic distribution system where you'll receive an email containing a link directly to the download site for the software.

To download Vocera software:

1. Open the email from Vocera containing download instructions.
2. Click the download link.
3. Review and accept the End User License Agreement.
Make sure the I confirm I have read and accept the statement box is checked.
4. Check the files and folders you want to download. Make sure you select the ISO image file (the file with the extension `.iso`), which contains the DVD contents.
5. Click **Download**.
6. Specify a location for the downloaded files.
7. After the download is finished, use a ZIP utility to extract the contents of the ISO image file, or use DVD burning software to burn the ISO image file to a DVD.



Note: If you burn a DVD, use DVD+R DL 8.5 GB media.

System Requirements

Learn about the requirements of the Vocera Voice Server Communication solution.

- [Server Requirements](#) on page 14
- [Infrastructure Requirements](#) on page 17
- [Configuration Hardware Requirements](#) on page 18
- [Browser Requirements](#) on page 19

Server Requirements

This section contains basic information about the Vocera Voice Server requirements.

For detailed information on supported operating systems, recommended sizing guidelines and more, see the [Vocera Voice Server Sizing Matrix](#).

Vocera Voice Server Requirements

Ensure that you install the Vocera software in a clean computer.

Use a dedicated computer to run the Vocera Voice Server. The computer should not run any other applications. If the computer has previously run other applications, you must re-install the operating system. Verify that appropriate service packs are installed.

Vocera SIP Telephony Gateway Requirements

Learn the requirements needed for setting up Vocera SIP Telephony Gateway.

Install the Vocera SIP Telephony Gateway on a dedicated computer. The Vocera SIP Telephony Gateway uses software that might cause conflicts, and it performs resource-intensive tasks that might affect performance of other applications.

The following figure shows a typical Vocera system consisting of Vocera Client Gateway, Vocera Voice Server, and Vocera SIP Telephony Gateway installed on separate computers. Optionally, Vocera Report Server can also be installed on a separate computer.

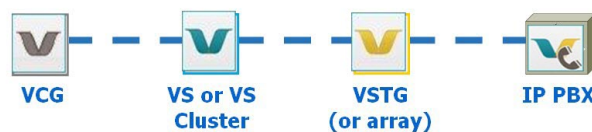

Figure 1: Vocera software installed on separate computers

If your PBX is not SIP-enabled or does not handle all SIP features such as RFC 2833 DTMF relay, you can use a VoIP media gateway (such as Dialogic Media Gateway) to connect to the PBX, as shown in the following figure.



Figure 2: VSTG connecting to PBX through Dialogic Media Gateway

If the computer on which you are installing Vocera SIP Telephony Gateway has previously run other applications, re-install the operating system and apply appropriate service packs to ensure you install the Vocera SIP Telephony Gateway into a clean environment.

Cisco Unified Communications Manager Support

Cisco Unified Communications (UC) is an IP-based communications system integrating voice, video, data, and mobility products and applications. It enables more effective, secure communications and can transform the way in which we communicate.

Vocera has tested Vocera SIP Telephony Gateway with the following versions of Cisco Unified Communications Manager:

- Cisco Unified Communications Manager version 8.5
- Cisco Unified Communications Manager Express (CME) version 7.1

Dialogic Media Gateway Support

Dialogic Media Gateway merge traditional PSTN technology with IP networks. The economical gateways help consolidate typically separate voice and data networks and provide new and differentiated communication services.

Vocera has tested Vocera SIP Telephony Gateway with digital and analog Dialogic Media Gateway models.

The following table displays the digital Dialog Media Gateway models.

SKU	Digital Gateway Description	Ports
235-02030	Dialogic DMG2030DTIQ – single T1/E1	30

The following table displays the analog Dialog Media Gateway models.

SKU	Analog Gateway Description	Ports
235-01004	Dialogic DMG1004LSW – 4 port analog	4
235-01008	Dialogic DMG1008LSW – 8 port analog	8

Vocera Client Gateway Requirements

Learn about installation considerations and requirements.

Install the Vocera Client Gateway on a dedicated computer. The Vocera Client Gateway uses software that might cause conflicts, and it performs resource-intensive tasks that might affect performance of other applications.

The following figure shows a typical Vocera system consisting of Vocera Client Gateway, Vocera Voice Server, and Vocera SIP Telephony Gateway installed on separate computers. Optionally, Vocera Report Server can also be installed on a separate computer.



Figure 3: Vocera software installed on separate computers

The Vocera Client Gateway must be installed with the same version as the Vocera Voice Server and the Vocera Client Gateway cannot communicate with earlier versions of Vocera Voice Server.

If the computer on which you are installing Vocera Client Gateway has previously run other applications, re-install the operating system and apply appropriate service packs to ensure you install the Vocera Client Gateway into a clean environment.

Vocera Report Server Limitations

The requirements needed for setting up Vocera Report Server is described in this topic.

Consider the following limitations when you install Vocera Report Server:

- Do not install more than one copy of the Vocera Report Server on your network.
- Do not install Vocera Report Server on a machine with dual network interface controllers (NICs). Only one NIC is supported.

The Vocera Report Server generates reports from logs and user data acquired from the Vocera Voice Server. The Vocera Report Server cannot communicate with earlier versions of the Vocera Voice Server.

Install the Vocera Report Server on a dedicated computer—it should not run any other applications. The Vocera Report Server uses software that might cause conflicts, and it performs resource-intensive tasks that might affect performance of other applications.

If the computer has previously run other applications, re-install the operating system and apply appropriate service packs to ensure you install the Vocera Report Server into a clean environment.



Infrastructure Requirements

Wired and wireless infrastructure may require minor configuration to accommodate the Vocera Communications System.

See the *Vocera Infrastructure Planning Guide* for complete information.



Configuration Hardware Requirements

Learn the requirements for Vocera badges and phones

The *configuration hardware* is the computer and other equipment that configures Vocera devices. The configuration computer is the computer on which you run the Vocera Badge Configuration Utility (BCU), so it is referred to as the BCU computer.

Vocera requires the following configuration hardware for badges and phones:

Table 1: Hardware requirements

Component	Requirement
Configuration Computer	See the Vocera Voice Server Sizing Matrix .
Access Point	An isolated access point that is not connected to the installation site's network.
Cable	An Ethernet crossover cable to connect the configuration computer and the access point.

Browser Requirements

Learn the Internet Explorer requirements needed to access Vocera Web applications.

To access Vocera Voice Web applications (Administration Console, User Console, Report Console, and Staff Assignment), your computer must have the following required software:

Table 2: Web application software requirements

Applications	Client-side component	Requirement
All applications	Browser	Internet Explorer versions 10 or later (Be sure that Compatibility Mode is turned off).



Important: Do not install another JRE on the Vocera Voice Server or Vocera Report Server machines. The required version of Java is installed with those servers.

Browser Recommendations and Requirements

Learn other important recommendations and tasks to internet and browser security.

The list below includes the configuration recommendations for Internet Explorer security settings. Required items are flagged.

- **Do not access a Vocera Voice Web application from the server on which it is running** – By default, Windows Server 2008 and Windows Server 2012 ship with Internet Explorer Enhanced Security Configuration enabled, which may display frequent security prompts when you access a Web application from the server on which it is running. Rather than disable Internet Explorer Enhanced Security Configuration on the server, we recommend that you access Vocera Voice Server Web applications from your desktop or laptop computer.
- **Configure the Internet Explorer security level to Medium-low or lower** – Otherwise, Internet Explorer prevents the scripts used by the consoles from executing completely. You can configure security settings through **Tools > Internet Options > Security** in Internet Explorer. See your Internet Explorer documentation for complete information.
- **Required: Disable the pop-up blocker** – Vocera consoles display information in pop-up windows, so disable pop-up blocking in Internet Explorer (that is, configure the browser to allow pop-up windows). Choose **Tools > Internet Options > Privacy**, and then uncheck the **Turn On Pop-Up Blocker** box.
If you are using a third-party tool to block pop-ups, refer to the tool's documentation.
- **Remove scroll bars from pop-up windows** – Pop-up windows may display scroll bars. To remove the scroll bars, choose **Tools > Internet Options > Security**, and select the **Local Intranet** zone. Click **Custom Level** to display the **Security Settings** dialog box. Enable **Allow script-initiated windows without size or position constraints**.

- **Required: If necessary, add the Vocera Voice Server and Vocera Report Server IP addresses to the list of Trusted Sites** – The security policy in certain situations may prevent you from setting the Internet Explorer security level for the local intranet below Medium. If Internet Explorer continues to display pop-up windows with scroll bars, follow these steps to configure a trusted site for the Vocera Voice Server:

To add the Vocera Voice Server and Vocera Report Server to the list of trusted sites:

1. In Internet Explorer, choose Tools > Internet Options. The Internet Options dialog box appears.
2. Click the Security tab.
3. Click Trusted Sites.
4. In the Security Level for this Zone box, set the security level to Medium-low, and click Apply.
5. Click the Sites button. The Trusted Sites dialog box appears.
6. Type the IP address of the Vocera Voice Server, and click Add.
7. Type the IP address of the Vocera Report Server, and click Add.
8. Click Close to close the Trusted Sites dialog box.
9. Click OK to close the Internet Options dialog box.

A system administrator can manage the Internet Explorer Trusted Sites for an entire organization using Group Policy Objects (GPOs).

- **If your Vocera Voice Server or Vocera Report Server has enabled SSL, configure Internet Explorer to NOT save encrypted pages to disk** – If you enable SSL on the Vocera Voice Server or Vocera Report Server, you may need to update the browser security settings for Internet Explorer to make sure the browser does delete cached-from-HTTPS resources when the browser is closed. Otherwise, certain pages of the Administration Console, such as the Permission Browser, will not work properly.

To update Internet Explorer security settings for SSL access:

1. In Internet Explorer, choose Tools > Internet Options > Advanced.
2. Make sure the Do not save encrypted pages to disk option is checked.
3. Click OK.

Upgrading an Existing Installation

Learn the steps that you need to follow to upgrade your Vocera Voice Server and Vocera Voice Server software components to version 5.2.3, and to update client devices and smartphones to the latest supported version of Vocera Firmware.

- [Before Upgrading](#) on page 22
- [Upgrading Vocera Voice Server to Version 5.2.3](#) on page 25
- [Upgrading Vocera Voice Server Components](#) on page 31
- [Changes in Behavior](#) on page 35
- [Suggested Post-Upgrade Tasks](#) on page 37

Before Upgrading

Learn the things you should consider before performing an Vocera Voice Server upgrade.

When you upgrade Vocera Voice Server to version 5.2.3, all of your data and settings are converted to the new Vocera Voice Server 5.2.3 format and your badge firmware is automatically upgraded.

Before performing an upgrade, please consider the following:

- For Vocera Voice Server, If Vocera Secure Texting (VST) is installed in your environment, you must uninstall the VST Sync Connector *before* you upgrade to the latest version of Vocera Voice Server. See "How to Uninstall the Vocera Secure Texting Sync Connector" in the *VST Administrator Guide*. Re-install the Sync Connector after you complete the Vocera Voice Server upgrade. Make sure that you download and install the latest version of the VST Sync Connector.
- For a Vocera Voice Server and Report Server upgrade from a 4.x version, be sure to obtain a new Vocera Voice Server license file before beginning the upgrade process. For more information, see the upgrade instructions specific to your environment under in [Upgrading Vocera Voice Server to Version 5.2.3](#) on page 25.
- Ensure that the server and operating system are capable of supporting Vocera Voice Server 5.2.3. See the [Vocera Voice Server Sizing Matrix](#).
- Refer to [Preparing the Vocera Voice Server](#) on page 39 to confirm that the server is set up properly.

Upgrade Considerations for a Standalone Environment

Learn important information to consider when upgrading the Vocera Voice Server in a standalone environment.

If you have a standalone Vocera Voice Server running Staff Assignment, Vocera recommends setting up a Vocera Voice Server cluster *before* upgrading to Version 5.2.3. If you want to upgrade from a standalone server to a cluster, you need additional machines. See [Active and Inactive Node Order](#) on page 23 for instructions on how to install the initial active node for a 5.2.3 cluster on new machines. For more information about setting up a cluster, see [Setting Up a Vocera Cluster](#) on page 77.



Important: This upgrade affects Vocera badges and client devices in the following ways:

- Users will experience a short outage (several minutes) while their badges connect to the upgraded 5.2.3 server for the first time and download new firmware. Plan for downtime accordingly.
- During the upgrade process, the server restores data from a backup file. Consequently, badges and client devices that are connected to the server while the upgrade is being performed, will be logged out automatically. Therefore, Vocera recommends that you warn Vocera users that after the firmware upgrade completes on their badge or device, they will need to log in again.

Upgrade Consideration for a Cluster: Planned Downtime

Learn important information to consider when upgrading the Vocera Voice Server in a clustered environment.

Plan for downtime as follows:

- Badge-to-badge calls: Users will experience a short outage (several minutes) while their badges connect to the upgraded 5.2.3 server for the first time and download new firmware.
- Badge-to-phone calls: Users will experience a longer outage while you upgrade the Vocera SIP Telephony Gateway.
- Learned names, learned commands, and pending deletes from upgrades for 4.x Versions: There is a brief period during the upgrade when learned names, learned commands, and pending deletions of Vocera Voice Server entities may not be synchronized with the standby Vocera Voice Server server. To avoid any problems, advise users not to record any learned names or learned commands and not to delete any entities during the entire upgrade.



Important: If you are concerned about possibly losing some learned names, learned commands, or pending deletes during the upgrade, you can shut down ALL Vocera Voice Server during the entire upgrade process. If you decide to do this, make sure you notify users of the planned outage.

Active and Inactive Node Order

Learn about inactive and active nodes when upgrading the Vocera Voice Server in a clustered environment.

When you perform this upgrade, the first Vocera Voice Server you configure becomes the initial active node in the 5.2.3 cluster. You should upgrade an inactive cluster node to 5.2.3 (leaving Vocera Voice Server running on the active node), move the badges over to this new 5.2.3 server, and then upgrade the remaining cluster node(s).

Consider the following:

- If you are setting up a cluster as you upgrade, the first machine that you configure becomes the initial active node.
- If your Vocera system has Vocera Messaging Interface (VMI) applications that connect to it, you need to coordinate with the integration developer to schedule updates to those applications before Vocera badge users can begin using the new system. VMI applications integrate the Vocera system with external systems (such as a nurse call system).



Important: This upgrade affects Vocera badges in the following ways:

- Users will experience a short outage (several minutes) while their badges connect to the upgraded 5.2.3 server for the first time and download new firmware.

Upgrade Considerations for the Report Server

Before upgrading the Report Server, think about performing basic maintenance tasks.

If the Report Server has a large amount of data that is several months old and is no longer needed to generate reports, you should consider archiving the older data up to a certain date. After the archive is saved, you can purge the old data, and then perform a backup.

Performing this kind of maintenance results in the following benefits:

- The number of records in the database will be reduced.
- The disk space required for scheduled backups will be reduced.
- The Report Server will use less processing power and RAM to generate reports, and it will generate them faster.
- The time needed to back up and restore Report Server data will be reduced.

For more information on how to archive and purge data, see the *Vocera Report Server Guide*.

Upgrading Vocera Voice Server to Version 5.2.3

The following section describe how to upgrade Vocera Voice Server to the latest Vocera software release.

Vocera Voice Server Upgrade Paths

You can upgrade to Vocera Voice Server version 5.2.3 from Vocera Voice Server 4.3 and greater. Upgrades from a version of Vocera Voice Server prior to 4.3 should be performed with assistance from Vocera Technical Support. For the latest information on the upgrade paths for this release, see the [Vocera 5.2.3 Release Notes](#).

Upgrading a Standalone Vocera Voice Server

Learn how to migrate your data and any custom configuration files with minimal downtime.

Before you begin: If Vocera Secure Texting (VST) is installed in your environment, you must uninstall the VST Sync Connector *before* you upgrade to the latest version of Vocera Voice Server. See "How to Uninstall the Vocera Secure Texting Sync Connector" in the *VST Administrator Guide*. Re-install the Sync Connector after you complete the Vocera Voice Server upgrade. Make sure that you download and install the latest version of the VST Sync Connector.

This topic provides the steps needed to upgrade from a standalone Vocera Voice Server system to a standalone Vocera Voice Server 5.2.3 system.

1. If Vocera Report Server is running, shut it down:
 - a. On the Vocera Report Server computer, choose **Start > All Programs > Administrative Tools > Services**.
The Services window appears.
 - b. Stop the Tomcat service.
 - c. Close the Services window.
2. Use the backup utility in your current Vocera installation to back up your data.
See [Backing up Vocera Data](#) on page 30.
3. (Optional for 5.1 or later) Uninstall the Vocera Voice Server software.
See [Uninstalling Vocera Voice Server Software](#) on page 72.



Note: You do not need to uninstall Vocera Voice Server software, if you are migrating from a Vocera 5.1 release to a later 5x release. However, if you are migrating from a Vocera release earlier than 5.1, this step is necessary. For example Vocera Voice Server 5.0 to 5.2.3 or 4.3 to 5.2.3.

4. Install the 5.2.3 Vocera Voice Server software.
See [Running the Vocera Voice Installation Program](#) on page 56.



Note: At the end of the installation program, *do not* reboot.

5. If your Vocera installation had a modified **Properties.txt** file, merge the changes into the corresponding file on your new server.
See [Upgrading Properties Files](#) on page 29.
6. Reboot the server you are upgrading.
7. After you reboot, the Vocera Voice Server automatically restores your Vocera database. When the restore completes, the badges will connect to the server and be able to communicate.
8. Perform the post-installation tasks to completely migrate your data from the previous Vocera version to 5.2.3:
 - a. See [Changes in Behavior](#) on page 35.
 - b. See [Suggested Post-Upgrade Tasks](#) on page 37.
9. Install or upgrade Vocera components on any other machines:

Component	Details
Badge Configuration Utilities	See the <i>Vocera Badge Configuration Guide</i> .
Vocera SIP Telephony Gateway	See Upgrading Vocera SIP Telephony Gateway on page 31
Vocera Client Gateway	See Upgrading Vocera Client Gateway on page 32.
Vocera Report Server	See Upgrading Vocera Report Server on page 32

Upgrading a Vocera Voice Server Cluster

Learn how to migrate your data and any custom configuration files with minimal downtime.

This topic describes how to upgrade from a Vocera Voice Server cluster to a Vocera Voice Server 5.2.3 cluster. For additional support, refer to the [Vocera Cluster Upgrade Checklist](#) on page 95.

1. If Vocera Report Server is running, shut it down:
 - a. On the Vocera Report Server computer, choose **Start > All Programs > Administrative Tools > Services**. The Services window appears.
 - b. Stop the Tomcat service.
 - c. Close the Services window.
2. Make sure Vocera badges are configured with the correct comma-separated list of IP addresses in the **Vocera Voice Server IP Address** property. If necessary, use the Badge Properties Editor to update the **badge.properties** file on every cluster node. For details, see the *Vocera Badge Configuration Guide*.
3. Shut down the standby Vocera Voice Server to make it inactive. If there are multiple standby Vocera Voice Servers, shut down ALL of them. This action does not affect the active Vocera Voice Server.

In the Vocera Control Panel, choose **Run > Shutdown**.

4. Upgrade the Vocera Voice Server on the inactive node as follows:
 - a. (Optional for 5.1 and later) Uninstall the Vocera 5.2.1 or Vocera 5.2.2 software on the inactive node.
See [Uninstalling Vocera Voice Server Software](#) on page 72.



Note: You do not need to uninstall Vocera Voice Server software, if you are migrating from a Vocera 5.1 release to a later 5x release. However, if you are migrating from a Vocera release earlier than 5.1, this step is necessary. For example Vocera Voice Server 5.0 to 5.2.3 or 4.3 to 5.2.3.

- b. Install the 5.2.3 Vocera Voice Server software.



Important: At the end of the installation program, *do not* reboot.

- c. If your Vocera installation has modified configuration files (for example, `Properties.txt`), merge the changes into the corresponding file on your new server. See [Upgrading Properties Files](#) on page 29.
- d. Reboot the server you are upgrading.



Important: After the Vocera Voice Server starts, it initially comes up as an **active** node, and then within a minute it rejoins the cluster and performs a remote restore. **DO NOT** proceed to the next step until after the remote restore finishes. With a large database, a remote restore can take several minutes. After the remote restore finishes, the server comes online as a **standby** node.

5. Shut down the Vocera Client Gateway and the Vocera SIP Telephony Gateway, as appropriate.

To shut down Vocera Client Gateway and Vocera SIP Telephony Gateway: Double-click the VSTG Service Stop and VCG Service Stop shortcut icon on the Windows desktop.



Note: If the active node is running Vocera Voice Server version 4.x then learned names and learned commands may not be synchronized from the active Vocera Voice Server to the standby 5.2.3 server.

6. In the Vocera Control Panel on the active node of the cluster, choose Run > Shutdown. In the confirmation dialog box, click OK.

Make sure the Vocera Voice Server node that has been updated to version 5.2.3 is now active.



Note: When the updated server becomes the active node, there is a **service interruption** as badges connect to the server and are updated. The badge update completes in approximately 5 minutes.

7. Upgrade the Vocera SIP Telephony Gateway and Vocera Client Gateway to version 5.2.3, as appropriate.

Component	Details
Vocera SIP Telephony Gateway	See Upgrading Vocera SIP Telephony Gateway on page 31.
Vocera Client Gateway	See Upgrading Vocera Client Gateway on page 32.

8. Upgrade the Vocera Voice Server on the inactive node as follows:
 - a. (Optional for 5.1 and later) Uninstall the Vocera 5.2.1 or Vocera 5.2.2 software on the inactive node.
See [Uninstalling Vocera Voice Server Software](#) on page 72.



Note: You do not need to uninstall Vocera Voice Server software, if you are migrating from a Vocera 5.1 release to a later 5x release. However, if you are migrating from a Vocera release earlier than 5.1, this step is necessary. For example Vocera Voice Server 5.0 to 5.2.3 or 4.3 to 5.2.3.

- b. Install the 5.2.3 Vocera Voice Server software.



Important: At the end of the installation program, *do not* reboot.

- c. If your Vocera installation has a modified `Properties.txt` file, merge the changes into the corresponding file on your new server. See [Upgrading Properties Files](#) on page 29.
 - d. Reboot the server you are upgrading.



Important: After the Vocera Voice Server starts, it initially comes up as an **active** node, and then within a minute it rejoins the cluster and performs a remote restore. **DO NOT** proceed to the next step until after the remote restore finishes. With

a large database, a remote restore can take several minutes. After the remote restore finishes, the server comes online as a **standby** node.

9. Upgrade Vocera Report Server as appropriate.
See [Upgrading Vocera Report Server](#) on page 32.
10. Perform the post-installation tasks to completely migrate your data to Vocera 5.2.3:
 - See [Changes in Behavior](#) on page 35.
 - See [Suggested Post-Upgrade Tasks](#) on page 37.

Upgrading Vocera Voice Server on a New Server

This section shows you how to upgrade, migrating your data and settings, with minimal down-time.

If you have an existing Vocera Voice Server system—standalone or cluster— install version 5.2.3 on new server.

1. Use the backup utility in your current Vocera Voice Server installation to backup your data.
See [Backing up Vocera Data](#) on page 30.
2. Copy any customized files to a flash drive or to a temporary location on a network drive that is accessible from your new Vocera Voice Server machine. For example:
 - `\vocera\backup\MostRecentBackup.zip`
If you are upgrading a Vocera cluster, this file is on any of the nodes.
 - `\vocera\config\badge.properties`
If you are upgrading a Vocera cluster, this file is on the active node.
 - `\vocera\server\Properties.txt`
If you are upgrading a Vocera Voice Server cluster, this file is on the active node.
3. Set up your new 5.2.3 server as follows:
 - a. Install the 5.2.3 Vocera Voice Server software.
At the end of the installation program, *do not* reboot.
 - b. If your Vocera installation had a modified `Properties.txt` file, merge the changes into the corresponding file on your new server.
See [Upgrading Properties Files](#) on page 29.
 - c. Copy `badge.properties` from your flash drive or network drive to the new `\vocera\config\` directory.
 - d. Copy `MostRecentBackup.zip` from your flash drive or network drive to the new `\vocera\backup\` directory.
 - e. Reboot the server you are upgrading.
After you reboot, the Vocera Voice Server automatically restores your Vocera database.
 - f. Perform the post-installation tasks to completely migrate your data to Vocera Version 5.2.3:
 - See [Changes in Behavior](#) on page 35.
 - See [Suggested Post-Upgrade Tasks](#) on page 37.
4. Install or upgrade Vocera components on any other machines:

Component	Details
Badge Configuration Utilities	See the Vocera Device Configuration Guide.
Vocera SIP Telephony Gateway	See Upgrading Vocera SIP Telephony Gateway on page 31.
Vocera Client Gateway	See Upgrading Vocera Client Gateway on page 32.

5. If Vocera Messaging Interface (VMI) client applications connect to your Vocera system, update them all. The VMI applications must be modified to connect to the new Vocera Voice Server IP address(es).

Before moving badges over to the new Vocera system, ensure that VMI applications are able to connect to the Vocera Voice Server and send messages.

6. Move the badges from your current production server to the 5.2.3 server that you just upgraded as follows:
 - a. Use the Badge Properties Editor to edit the **Vocera Voice Server IP Address** field in the `\vocera\config\badge.properties` file that resides on your production Vocera system.
Enter the IP address of the 5.2.3 server that you just upgraded. If you are creating a cluster, this becomes your initial active node. Make sure you update the **Vocera Voice Server IP Address** field for all types of badges. See the Vocera Device Configuration Guide.
 - b. Restart your production Vocera Voice Server, as described in [Stopping and Restarting the Server](#) on page 92.
When the Vocera Voice Server restarts, it downloads the edited `badge.properties` file to your existing badges, and then they automatically connect to the 5.2.3 system. The 5.2.3 server is now your production system.
 - c. Leave your existing Vocera Voice Server running, even though the currently active badges are not connected to it.
When users boot badges that haven't been used recently, they will connect to the Vocera Voice Server at that IP address, download the new `badge.properties` file, and then connect to the current 5.2.3 server.
7. If you are migrating to a cluster, use the cluster setup documentation to configure the remaining nodes.
See [Setting Up an Initial Cluster Configuration](#) on page 79.

Upgrading Properties Files

Learn the steps to upgrade the Vocera Voice Server and Vocera Voice Server components properties files.

The following files define properties for Vocera Voice Server and Vocera SIP Telephony Gateway.

Product	Properties File
Vocera Voice Server	<code>\vocera\server\properties.txt</code>
Vocera SIP Telephony Gateway Vocera Client Gateway	<code>\vocera\telephony\vgw\vgwproperties.txt</code>

These files provide default values that are appropriate for most installations.

If you have edited one or both of these files to specify specialized behavior, this topic tells you how to preserve these changes when you migrate to Vocera 5.2.3. If you have not changed the default values in these files, you do not need to perform this task.

To upgrade the property files:

1. Find your customized Vocera property files from the previous release.
You copied these files to a flash drive or to a temporary location on a network drive before installing Vocera 5.2.3.
2. Find the new property files in the locations specified above.
3. Merge the changed data from the backup files into the new files.
Several text editors—especially programs designed for editing source code—provide a merge feature. You can also copy and paste the data by hand.



Note: Vocera 5.2.3 has a new speech recognition engine that does not require the `SysRecParms` or `SysFreqDeptRecParms` properties. If you have set these properties, comment them out; Vocera 5.2.3 does not recognize them.

4. To load the updated **properties.txt** file, restart the Vocera Voice Server(s).
If you have a Vocera Voice Server cluster, restart the standby node(s) first. The standby node(s) automatically perform a remote restore. After remote restore is completed on the standby node(s), force a failover on the active node by choosing **Cluster > Failover** in the Vocera Control Panel.
5. To load the updated **vgwproperties.txt** restart the Vocera Client Gateway server(s).
If you have multiple Vocera SIP Telephony Gateway servers, restart one server at a time. Wait until the server has started before restarting the next server in the array until all servers have been restarted.

Backing up Vocera Data

Use the Vocera backup utility to backup existing data. After an upgrade, the Vocera Voice Server restores backed up data the first time you launch it.

To back up Vocera data:

1. Launch the Administration Console on your Vocera Voice Server system.
2. Click the Maintenance button in the navigation bar to display the set of Maintenance tabs. By default, the Server page is already selected.
3. Click the Backup button.
Vocera backs up your configuration data to a file in the **\vocera\backup** directory of the server computer and displays a dialog box to show you the progress. When the backup is finished, Vocera displays the progress as 100%.
4. Click OK to close the dialog box and return to the Administration Console.
5. If your Vocera installation has a modified **\vocera\server\properties.txt** or **\vocera\telephony\vgw\vgwproperties.txt** file, back up the file to a flash drive or to a temporary location on a network drive.
After you install Vocera 5.2.3, you will need to merge the changes into the corresponding file on your upgraded Vocera Voice Server.

Upgrading Vocera Voice Server Components

This section describes how to upgrade Vocera Voice Server products to version 5.2.3.

Upgrading Vocera Staff Assignment

Staff Assignment is automatically installed with Vocera Voice Server 5.2.3. After you upgrade the Vocera Voice Server to Version 5.2.3 and then restart the computer, the Vocera Voice Server performs a remote restore (if you have a Vocera cluster) or restores data from a backup file (if you have a standalone Vocera Voice Server). The Staff Assignment application data and certificate file are also restored.



Important: If you have a standalone Vocera Voice Server running Staff Assignment, Vocera recommends setting up a Vocera Voice Server cluster *before* upgrading to Version 5.2.3. Otherwise, badges will be logged out automatically when they connect to the 5.2.3 server for the first time. Also, if bed/room groups and role-based groups have been configured to remove users on logout, all staff assignments for the current shift will be cleared during the Vocera Voice Server upgrade.

Standard and Premier

Learn which version of Staff Assignments is right for your environment.

Staff Assignment has two versions, Standard and Premier:

- **Staff Assignment Standard** allows you to use basic staff assignment features. There is no charge for Staff Assignment Standard; it is included with Vocera Voice Server.
- **Staff Assignment Premier** provides several additional communication, user interface, and session management features, and requires client application licenses on the Vocera Voice Server. To obtain additional licenses, contact Vocera. If the Vocera Voice Server does not have client application licenses available for Staff Assignment Premier, users will log in with Staff Assignment Standard functionality.

For instructions on how to update your Vocera Voice Server license, see the *Vocera Installation Guide*, in the topic titled, "Manually Installing the Vocera License File".

Upgrading Vocera SIP Telephony Gateway

Learn the steps for performing an upgrade to Vocera SIP Telephony Gateway.

If you have an array of Vocera SIP Telephony Gateway servers, perform these upgrade steps on each server.

To upgrade the Vocera SIP Telephony Gateway:

1. If your Vocera 5.2.1 or Vocera 5.2.2 installation has a customized Vocera SIP Telephony Gateway properties file (`\vocera\telephony\vgw\vgwproperties.txt`), back up the file to a flash drive or to a temporary location on a network drive.

After you install Vocera 5.2.3, you will need to merge the changes into the corresponding file on your upgraded Vocera SIP Telephony Gateway.

2. (Optional for 5.1 or later) Uninstall the existing Vocera SIP Telephony Gateway. See [Uninstalling Vocera Voice Server Software](#) on page 72.



Note: You do not need to uninstall Vocera SIP Telephony Gateway software, if you are migrating from a Vocera 5.1 release to a later 5x release. However, if you are migrating from a Vocera release earlier than 5.1, this step is necessary. For example Vocera SIP Telephony Gateway 5.0 to 5.2.3 or 4.3 to 5.2.3.

3. Install the new Vocera SIP Telephony Gateway. See [Running the Vocera SIP Telephony Gateway Installation Program](#) on page 68.
4. If you have a customized Vocera SIP Telephony Gateway properties file (`\vocera\telephony\vgw\vgwproperties.txt`) from a previous deployment, merge the changes into your current `vgwproperties.txt` file.
See [Upgrading Properties Files](#) on page 29.

Upgrading Vocera Client Gateway

Learn the steps for performing an upgrade to Vocera Client Gateway.

With Vocera 5.2.3, you can take advantage of high availability features by installing multiple Vocera Client Gateway servers. See [Installing Multiple Vocera Client Gateway Servers](#) on page 54.

To upgrade the Vocera Client Gateway:

1. If your Vocera installation has a customized Vocera Client Gateway properties file (`\vocera\telephony\vgw\vgwproperties.txt`), back up the file to a flash drive or to a temporary location on a network drive.

After you install Vocera 5.2.3, you will need to merge the changes into the corresponding file on your upgraded Vocera Client Gateway.

2. (Optional for 5.1 or later) Uninstall the existing Vocera Client Gateway.
See [Uninstalling Vocera Voice Server Software](#) on page 72.



Note: You do not need to uninstall Vocera Client Gateway software, if you are migrating from a Vocera 5.1 release to a later 5x release. However, if you are migrating from a Vocera release earlier than 5.1, this step is necessary. For example Vocera Client Gateway 5.0 to 5.2.3 or 4.3 to 5.2.3.

3. Install the new Vocera Client Gateway.
See [Running the Vocera Client Gateway Installation Program](#) on page 61.
4. If you have a customized Vocera Client Gateway properties file (`\vocera\telephony\vgw\vgwproperties.txt`) from a previous deployment, merge the changes into your current `vgwproperties.txt` file.
See [Upgrading Properties Files](#) on page 29.
5. After you upgrade to Vocera 5.2.3, update your client devices to the latest firmware. See the related to your device, Vocera Collaboration Suite Apple iOS User Guide, Vocera Collaboration Suite Android User Guide and the Vocera Device Configuration Guide.

Upgrading Vocera Report Server

Learn the steps for performing an upgrade to Vocera Report Server.

This section describes how to upgrade Vocera Report Server from a previous release.

To upgrade to Vocera Report Server 5.2.3:

1. Upgrade to Vocera Voice Server version 5.2.3.
For upgrade instructions, see [Upgrading Vocera Voice Server to Version 5.2.3](#) on page 25.
2. Prepare the Vocera Voice Server.
See [Preparing the Vocera Voice Server](#) on page 39.
3. Perform basic maintenance of your Report Server to purge old data and reduce the size of the data set.
See [Upgrade Considerations for the Report Server](#) on page 23.
4. Make sure your report data is backed up. Normally, a backup is scheduled to occur every night. Check the `\vocera\reports\backup` folder to see that the backup file exists.
5. If you have custom reports, create a back up of the following folder:
`\vocera\reports\Reports\custom`
6. (Optional for 5.1 or later) Uninstall Vocera Report Server.



Note: You do not need to uninstall Vocera Report Server software, if you are migrating from a Vocera 5.1 release to a later 5x release. However, if you are migrating from a Vocera release earlier than 5.1, this step is necessary. For example Vocera Report Server 5.0 to 5.2.3 or 4.3 to 5.2.3.

See [Uninstalling Vocera Voice Server Software](#) on page 72.



Important: Do not delete any of the remaining directories or files from your Vocera Report Server installation. They will be used to restore your data when upgrading.

7. Install Vocera Report Server 5.2.3.
See [Running the Vocera Report Server Installation Program](#) on page 64.
8. Restore your report data:
 - a. Log into the Vocera Report Console using the default **admin** password.
After you restore your report data, your custom password (if any) is restored.
 - b. Click Maintenance in the navigation bar.
 - c. If you are upgrading from versions prior to 4.4.2 Click Legacy Restore.
The Select Restore Files dialog box opens.
 - d. Click a file name in the dialog box to choose a backup file.
 - e. Click Restore.
Another dialog box warns you that the operation will temporarily stop the server and system data will be replaced.
 - f. Click OK to restore data.
When you click OK, the process begins, and a dialog box displays status messages.
 - g. When the process is complete, click OK to close the dialog box.
9. If you have custom reports, follow these steps to restore them:
 - a. Copy the contents of the backup you made of the `\vocera\reports\Reports\custom` folder.
 - b. Paste the files into the `\vocera\reports\Reports\custom` folder.
 - c. Choose Start > Settings > Control Panel > Administrative Tools > Services. The Services window appears.
 - d. Stop the Tomcat7 service and then start it again.
 - e. Close the Services window.

Upgrading Vocera Administration Interface Applications

Learn about performing an upgrade to Vocera Administration Interface(VAI).

If you have deployed VAI applications, the voice server provides backwards compatibility for these applications.

The Vocera 5.2.3 `server.jar` file is compiled using Java 8.0 (1.8). If your VAI application needs to be updated to take advantage of new functionality and if the VAI application is not running under an earlier version of Java than 1.8, be sure to update the VAI application to run under Java 1.8.

In addition, the Vocera 5.2.3 `server.jar` file has some dependent libraries that exist in the `%vocera_drive%\vocera\server\lib` folder that need to be copied. The files that need to be copied include:

- `crypto-1.1.2.jar`
- `slf4j-api-1.7.7.jar`
- `commons-configuration-1.10.jar`
- `commons-lang-2.6.jar`
- `commons-io-2.4.jar`
- `commons-lang-2.6.jar`

See the *Vocera Administration Interface Developer Guide* for details.



Important: VAI applications that connect to Vocera Voice Server 5.2.3 must use Java Runtime Environment (JRE) 8.0 (1.8).



Changes in Behavior

This topic summarizes the changed behavior between earlier versions of Vocera Voice Server and latest version of Vocera Voice Server.

Changes in behavior between releases which may require you to modify your configuration after you install.

The following changes in behavior occurred between Vocera 4.3 and Vocera 4.4, and Vocera 5.2.3:

- **Qos Manager Installs with Vocera Voice Server, Vocera SIP Telephony Gateway and Vocera Client Gateway** – The Vocera QoS Manager, which prioritizes voice packets over the network, is now installed with the Vocera Voice Server, Vocera SIP Telephony Gateway, and Vocera Client Gateway.
- **Recorded Genie prompts** – Users may notice a change in the Genie's voice. All English Genie prompts, both male and female, have been re-recorded using different voice-over talents. Several new prompts have been added.
- **Faster call announcements** – Call announcements are much shorter, saving users valuable time. It may take a few calls for users to adjust to the shorter call announcement. The response to the prompt (Yes or No, using a voice response or buttons) has not changed.
- **Recorded name reminder** – If users have not recorded their name, the Genie reminds them to record one at the next login.
If you'd rather not remind users to record their names, you can disable the system preference for this feature.
- **Active Directory authentication** – If Active Directory authentication is enabled in the Administration Console, users must log into the Administration Console, User Console, and Staff Assignment using their Active Directory credentials.
If you enable Active Directory authentication, make sure you notify users of the change. Otherwise, they may try to log in using their Vocera user ID and password.
- **Change if “Announce Caller's Name After Tone” is NOT selected** – There is a change in behavior when the “Announce Caller's Name after Tone” default setting is NOT selected. With Vocera 4.3, the recipient of a call heard only a chime to announce the call. With Vocera 5.2.3, the recipient of a call now hears a chime plus “Accept call?”
- **Changes to the Badge Properties Editor** – To simplify the Badge Properties Editor user interface and make it easier to configure badges for today's wireless networks, several badge properties have been removed. The removed properties are still supported and their default values have not changed. For details, see the *Vocera Badge Configuration Guide*.
- **Vocera Report Server Diagnostic reports removed** – The Diagnostic reports, which were deprecated in Vocera Report Server 4.3 and replaced by the Speech Reports, have been removed from the product. Make sure these reports are not used in any of your scheduled report packages.
- **Smaller Vocera Voice Server backup files** – Due to optimization of entity prompts, Vocera Voice Server backup files may be noticeably smaller after you upgrade to Version 5.2.3.

- **Changes made to the signaling between badges and the server** – Users will experience a short outage (several minutes) while their badges connect to the upgraded 5.2.3 server for the first time and download new firmware. Due to changes made to the signaling between badges and the server, the badges cannot download the new firmware in the background. Plan for downtime accordingly. Subsequent badge firmware updates that don't involve a signaling change should occur in the background.



Suggested Post-Upgrade Tasks

After you install the latest software, consider taking advantage of some of the more powerful new 5.2.3 features by performing the tasks in the following list.

Vocera recommends performing the following post-installation tasks after you upgrade to Vocera Voice Server version 5.2.3:

- If your organization uses Vocera Messaging Platform, which provides enterprise messaging and alerting capabilities, consider integrating it with your Vocera Voice Server. For details, see the *Vocera Administration Guide*.
- After you upgrade to Vocera Report Server 5.2.3, check the Task Scheduler settings for the backup, dataload, and sweep tasks to make sure they are correct. You may also want to schedule archive and purge tasks.

For more information about the Task Scheduler, see the *Vocera Report Server Guide*.



Note: This section is not all-inclusive—see the Release Notes for a complete list of new features in version 5.2.3.

Installing on a New Server

This section include Installation instructions and considerations for new Vocera Voice Server and Vocera Voice Server software components.

- [Preparing for a New Installation](#) on page 39
- [Installing Vocera Voice Server Software](#) on page 56
- [Installing Vocera Voice Server Software Components](#) on page 61
- [Uninstalling Vocera Voice Server Software](#) on page 72

Preparing for a New Installation

If you are installing Vocera Voice Server or Vocera Voice Server software components for the first time on a new server, following these instructions.

Preparing the Vocera Voice Server

Learn server configuration considerations before installing or upgrading Vocera Voice Server software.

Before installing Vocera Voice Server software, make sure that the server is configured properly:

- Make sure the Windows Installer service is enabled. See [Enabling Windows Installer](#) on page 40.
- Make sure the built-in Windows DHCP server is not running on the Vocera Voice Server machine. See [Removing the Windows DHCP Server](#) on page 40.
- Make sure the Windows Update software does not apply updates automatically. See [Configuring Windows Update](#) on page 40.
- Configure Windows processor scheduling and memory usage for the best performance of programs. See [Configuring Performance Options](#) on page 40.
- Synchronize the clocks of each server in a Vocera Voice Server cluster. See [Synchronizing Cluster Server Clocks](#) on page 41.

Vocera SIP Telephony Gateway Architecture

Learn about the about topology for Vocera SIP Telephony Gateway.

Vocera SIP Telephony Gateway is a SIP telephony gateway between the Vocera Voice Server and an IP PBX or a VoIP gateway.

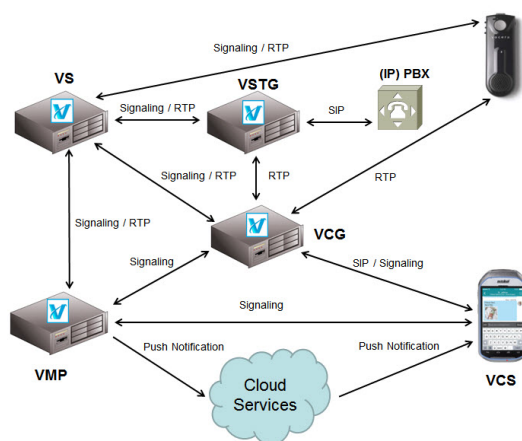

Figure 4: Vocera SIP Telephony Gateway architecture

Enabling Windows Installer

The Vocera installation program requires the Windows Installer service.

The Microsoft Windows Installer is a service of the Windows operating system that simplifies application installation. By default, Microsoft installs and enables this service as part of the operating system installation.

If you have disabled this service for some reason, the Vocera installation will display a dialog box notifying you of this requirement and then exit.

1. From the Windows **Start** menu, select **Settings > Control Panel > Administrative Tools > Services**.

The Services dialog box appears, displaying the list of installed Windows services.

2. Double-click the **Windows Installer** service.

The Windows Installer Properties dialog box appears. By default, the General pane is visible.

3. Make sure the value of the **Startup Type** field is set to **Manual**, and set it if necessary.

4. Click **OK**.

The Windows Installer Properties dialog box closes, saving your changes.

Removing the Windows DHCP Server

Learn about the problems associated with running Windows DHCP.

Do not run the built-in Windows DHCP server on the Vocera Voice Server machine. Although the DHCP server does not typically require significant system resources, running it on the Vocera Voice Server computer causes significant problems in a clustered environment, including the following:

- Devices may inadvertently receive duplicate IP addresses.
- Badges may not receive an IP address and get stuck displaying "Requesting IP Address".
- Badges may get invalid and unusable IP address information.

If the Windows DHCP server is running on the Vocera Voice Server computer, use the Windows Control Panel to remove it.

Configuring Windows Update

If your server computer uses the Windows Update software to keep its components up-to-date, make sure it does not apply these updates automatically.

Many server computers use the Windows Update software to keep their operating systems, software, and hardware up to date. If Windows Update is set to apply updates automatically, it may reboot your server as part of the update process. This forced system reboot may result in a Java exception, because Windows Update did not shut down all the server processes properly.

You can configure Windows Update to download any updates automatically, but apply the updates yourself after you shut down the Vocera Voice Server and its related services properly.

Configuring Performance Options

Learn the steps to set Windows performance options for Vocera Voice Server.

Nuance Speech Recognition, Verifier, and Vocalizer software work best when the server is set to give the best performance to Programs rather than Background Services.

In Programs mode, Windows provides more frequent but smaller time slices during thread switching. In Background Services mode, Windows provides longer and less frequent time slices. If you run Windows with Background Services mode, Vocera badges may experience choppy audio.

To set Windows performance options for the Vocera Voice Server:

1. Choose Start > Settings > Control Panel > System. The System Properties dialog box appears.
2. Click the *Advanced* tab.
3. In the Performance box, click *Settings*. The Performance Options dialog box appears.
4. Click the *Advanced* tab.
5. In the Processor Scheduling box, click *Programs*. This gives more processor resources to the Vocera Voice Server instead of background services.
6. In the Memory Usage box, click *Programs*. This allocates more system memory to the Vocera Voice Server instead of the system cache.
7. Click *OK*.
8. A dialog box informs you that the changes will not take effect until you restart the computer. Click *OK* to close the dialog box.
9. In the Performance Options dialog box, click *OK*.
10. In the System Properties dialog box, click *OK*.
11. Restart the computer.

Synchronizing Cluster Server Clocks

Standardizing the time zones using these steps to allow the log files to be time stamped uniformly for failover purposes and also enables the Vocera Genie to say the actual correct time in voice prompts that users hear.

If you are planning to deploy a Vocera cluster, best practice is to synchronize the clocks on each server in the cluster. You are not required to synchronize the clocks to support cluster failover; however, if the clocks are set to different times, troubleshooting with system log files and analyzing Vocera Report Server log files becomes difficult after a failover.

If the servers physically reside in different time zones, you should set them all to a single time zone at the operating system level, then use Vocera to specify the actual time zone for each site.

To synchronize cluster server clocks:

1. At the operating system level, set each server in the cluster to the same time zone. See your operating system documentation for additional information.
2. Synchronize the clocks in every server in the cluster. For example, you can make sure the clocks are synchronized in one of the following ways:
 - Set the clock of each server in the cluster to sync to the same internet time source.
 - Use the Windows Time service to make sure that each server in the cluster uses a common time.
 See your operating system documentation for additional information.
3. After Vocera Voice Server is installed, use the Sites screen to specify the time zone of every site. See the *Vocera Voice Server Administration Console Guide* for complete information.

Preparing the Vocera SIP Telephony Gateway

Learn about the Vocera SIP Telephony Gateway architecture and system requirements, and about the tasks and procedures to perform before you install the Vocera SIP Telephony Gateway.

About Vocera SIP Telephony Gateway

Learn about the architecture, signaling, features, and benefits of the Vocera SIP Telephony Gateway.

Vocera SIP Telephony Software Benefits

Learn the benefits associated with integrating Vocera Voice Server with your phone system.

The Vocera SIP Telephony Gateway software provides seamless calling between Vocera badges and telephones, expanding the reach of the Vocera system to people outside the wireless network. Both Vocera SIP Telephony Gateway support installation of multiple telephony servers for N + 1 redundancy, scalability, and load balancing. When you integrate the Vocera Voice Server with the corporate telephone system:

- Telephone callers outside the Vocera system can place calls to users' badges.
The Vocera Genie answers calls and prompts the callers to speak the name of the person or group they want to reach. If no one answers, the caller can leave a message or try someone else.
- Users can call telephones from their badges.
Voice commands let users call internal extensions, local phone numbers, and long-distance numbers. You control which groups of users have permissions to make each type of call in the Administration Console.
- Users can forward incoming badge calls to an extension, an outside telephone number, or a voicemail box.
Callers can reach badge users who are at home, traveling, or telecommuting. Voice commands let users specify where and when to forward calls. See the *Vocera Badge User Guide* for a description of voice commands for forwarding.
- Unanswered calls to a group can be forwarded to a telephone.
The system administrator or a group manager can configure groups to make Vocera forward their calls to special numbers, such as the switchboard operator or the telephone number of an individual group member. For example, if all members of the "Tech Support" group are busy or off-network, Vocera can forward a call to the cell phone or contact number of the group member who is "on call."
- Users can place phone calls through their badges by speaking the names of people or places, instead of their phone numbers.
The address book lets you define the names and contact phone numbers for people and places who are not in the Vocera system. These names are then available to all users on the system. For example, outside assistance is immediately available to a badge user who says, "Call Poison Control". Individual users can also set up personal outside buddies, and place phone calls to them by name.
- Users can transfer calls from their badges to telephone extensions.
Users who receive calls on their badges can optionally transfer them to telephone extensions with a simple voice command. For example, if more privacy is required, users can transfer a call to a telephone extension in a more private location.
- Users can send and receive pages.
Users can send pages to other badge users. Users with the proper permissions can use voice commands to control whether they want to receive pages at any time.

Vocera SIP Telephony Gateway provides the following *additional* benefits:

- Reduced call latency
- Software-only solution (no Dialogic card required)
- Less cabling, not required to be near PBX
- Support for deployment in a VMware virtualized environment
- Vocera Access Anywhere (phone access to the Vocera Genie) for all users

Vocera SIP Telephony Gateway Architecture

Learn about the about topology for Vocera SIP Telephony Gateway.

Vocera SIP Telephony Gateway is a SIP telephony gateway between the Vocera Voice Server and an IP PBX or a VoIP gateway.

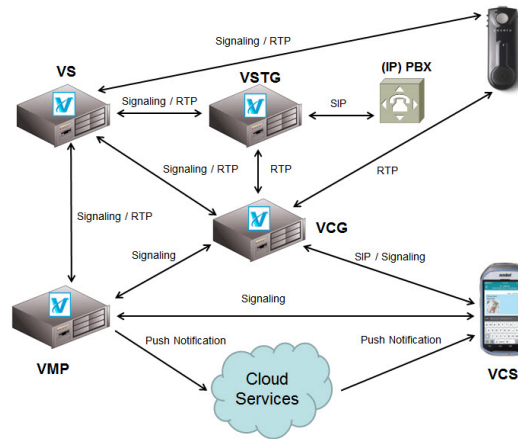

Figure 5: Vocera SIP Telephony Gateway architecture

Session Initiation Protocol Support

Vocera SIP Telephony Gateway is based on Internet Engineering Task Force (IETF) standards for Session Initiation Protocol (SIP) 2.0 and Real Time Transport Protocol (RTP).

Vocera SIP Telephony Gateway communicates via a SIP trunk with a SIP-enabled PBX or a SIP Gateway. The Vocera SIP Telephony Gateway provides basic SIP telephony functionality, including placing and receiving calls, OPTIONS keep-alive messages, and obtaining ANI and DNIS information. The Vocera SIP Telephony Gateway is interoperable with SIP-enabled PBXs and SIP Gateways as long as they follow SIP 2.0 and RTP standards.

For audio transport, Vocera SIP Telephony Gateway uses Real-time Transport Protocol (RTP), an Internet protocol standard for delivering multimedia data over unicast or multicast network services (see [RFC 3550](#) and [RFC 3551](#)).

Vocera Voice Server uses Vocera's proprietary signaling and transport protocols for all communication between the server and Vocera badges. Consequently, Vocera SIP Telephony Gateway converts from SIP/RTP protocols to Vocera's protocols, and vice versa, to enable communication between the Vocera Voice Server and the IP PBX.

Outgoing Calls

Learn about outgoing call requests in the Vocera environment.

When the Vocera Voice Server receives an outgoing call request, it passes the dialing sequence to the Vocera SIP Telephony Gateway, which performs the call setup, connects to the PBX or other telephone system and dials the outgoing call.

Once a call is established, badges participating in the call communicate directly with the Vocera SIP Telephony Gateway without going through the Vocera Voice Server.

Incoming Calls

The Vocera SIP Telephony Gateway answers incoming calls and routes the calls to the Vocera Voice Server.

On the Vocera Voice Server, the Genie prompts the caller for the name of a user or group. The Vocera Voice Server then attempts to route the call to the appropriate badge:

- If the badge user is available, the badge communicates with the telephone through the Vocera SIP Telephony Gateway, without going through the Vocera Voice Server.
- If the badge user is not available, the Vocera Voice Server checks the forwarding option for the user or group and processes the call accordingly.

If a call cannot be forwarded, the Genie invites the caller to leave a message.

Using the SIP Testing Tool

Before installing Vocera SIP Telephony Gateway, Vocera recommends testing the SIP connection to your PBX using a SIP Testing Tool that it provides.

The SIP Testing Tool allows you to test the following SIP functionality:

- Place a SIP test call to the PBX.
- Receive a SIP call from the PBX (requires a SIP handset or soft phone).
- Test whether OPTIONS keep-alive is working.

For more information about the SIP Testing Tool, see KB1086 in the Vocera Technical Support Knowledge Base.

You can download the SIP Testing Tool from the following location:

http://www.vocera.com/ts/VSTG_siptest/siptest.zip



Important: Make sure the Vocera SIP Telephony Gateway is not running on the computer on which you run the SIP Testing Tool.

Vocera SIP Telephony Gateway License Requirements

Learn about the license requirements when using SIP Telephony with Vocera Voice Server.

To use Vocera SIP Telephony Gateway as the telephony server for your Vocera system, you must meet the following license requirements:

- Obtain a SIP telephony license from Vocera.
- Update each Vocera Voice Server with the new Vocera license (see the *Vocera Installation Guide*, in the topic titled, Manually Installing the Vocera License File.



Important: If you do not meet these license requirements, the Vocera SIP Telephony Gateway will not start, and the Vocera Voice Server will be unable to connect with the Vocera SIP Telephony Gateway.

Telephony SIP Deployment Scenarios

This section described the single and multiple site scenarios.

With the high availability features provided for the Vocera SIP Telephony Gateway there are several telephony deployment scenarios. Scenarios are based on whether your enterprise fully takes advantage of these features, and also based on the following factors:

- number of Vocera sites
- number of PBXs at those sites
- mission criticality of the Vocera system
- capital budget limits

Single Site Scenarios

The simplest single site deployment scenario has one Vocera Voice Server connected to one telephony gateway using one PBX.

This scenario does not take advantage of any high availability features, such as redundancy, scalability, and load balancing.

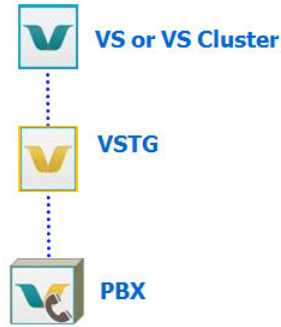

Figure 6: Single Site Scenario with 1 telephony gateway

Summary	
Sites:	1
Telephony Sharing:	No
PBX Failover:	No
High Availability:	No

To add high availability to a single site Vocera system, an array of telephony gateways can be installed, and two SIP trunks can be used to provide failover support. This scenario provides redundancy, scalability, and load balancing. The Vocera Voice Server handles outbound load balancing by automatically allocating calls to the least busy telephony gateway. The PBX handles inbound load balancing.

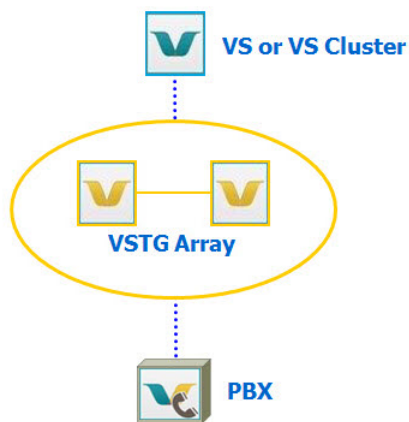

Figure 7: Single Site Scenario with a telephony gateway Array

Summary	
Sites:	1
Telephony Gateway Sharing:	No
PBX Failover:	Yes

Summary	
High Availability:	Yes

Multiple Site Scenarios

More complex deployment scenarios include multiple sites, shared gateways, and PBXs.

With multiple sites, the complexity of telephony deployment scenarios increases due to the following factors:

- Option of installing redundant telephony gateways at each site for high availability
- Option of sharing telephony gateways between sites
- Potentially multiple PBXs

The following scenario shares telephony gateways between sites. In this example, the telephony gateway uses the PBX at site A. The telephony gateway is shared with site B, which may or may not have its own PBX. Because a single telephony gateway instead of an array of telephony gateways is installed at site A, high availability features are not supported.

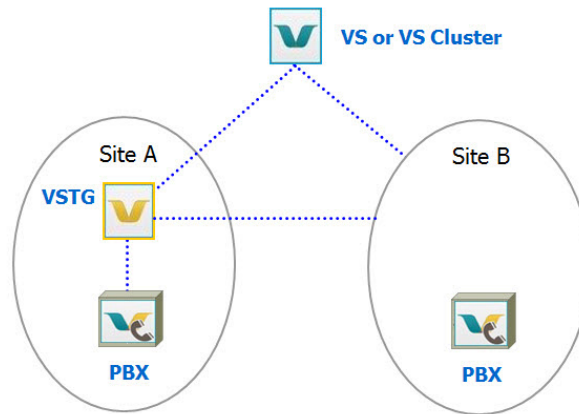

Figure 8: Multiple Site Scenario Using a Shared Telephony Gateway and 1 PBX Per Site

Summary	
Sites:	Multiple
Telephony Sharing:	Yes
PBX Failover:	No
High Availability:	No

The following scenario is a variation of the previous one. An array of telephony gateways has been added, which provides redundancy, scalability, and load balancing.

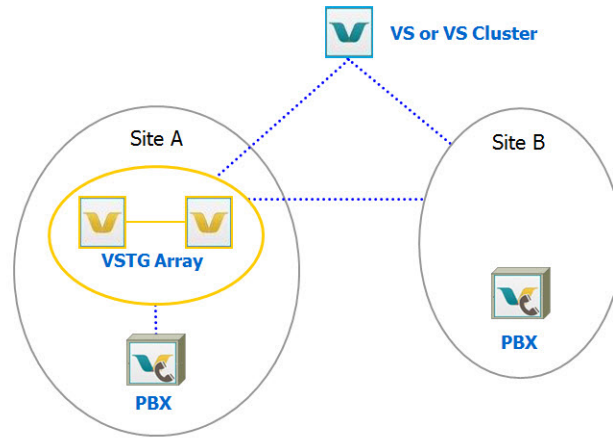

Figure 9: Multiple Site Scenario Using a Shared Telephony Gateway Array and 1 PBX Per Site

Summary	
Sites:	Multiple
Telephony Gateway Sharing:	Yes
PBX Failover:	No
High Availability:	Yes

The following scenario has a telephony gateway and PBX at each site. Using independent telephony gateways instead of sharing a telephony gateway between sites may be needed for performance and scalability. Because a single telephony gateway is installed at each site instead of an array of telephony gateways, high availability features are not supported.

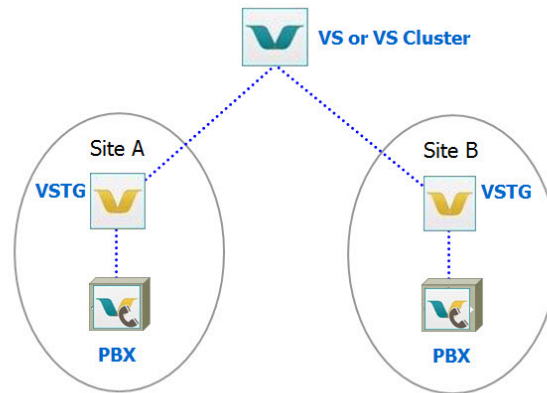

Figure 10: Multiple Site Scenario Using a telephony gateway and PBX at Each Site

Summary	
Sites:	Multiple
Telephony Gateway Sharing:	No
PBX Failover:	No
High Availability:	No

The following multiple site scenario represents the best practice for high availability support. It has an array of telephony gateways and redundant PBXs at each site.

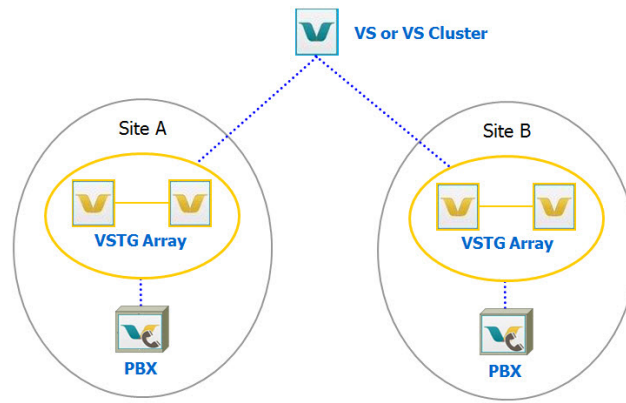

Figure 11: Multiple Site Scenario Using 2 Telephony Gateways and 2 PBXs at Each Site

Summary	
Sites:	Multiple
Telephony Gateway Sharing:	No
PBX Failover:	Yes
High Availability:	Yes

This next scenario is an option for multiple sites where one site uses Vocera Voice Server as a mission critical application, and the other site does not (perhaps because it is a small test deployment). In this example, an array of telephony gateways and two PBXs are installed at site A but not at site B. Therefore, only site A has high availability features.

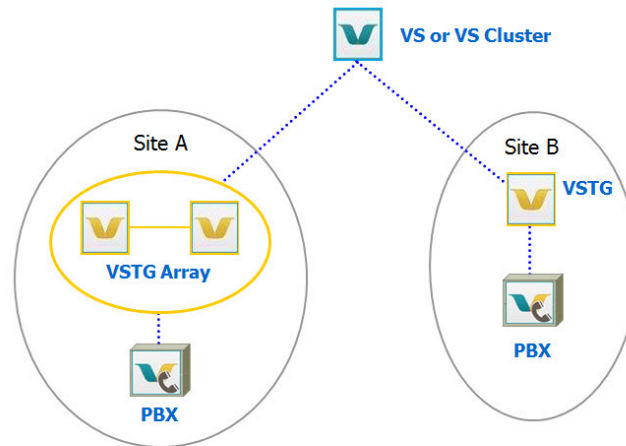

Figure 12: Multiple Site Scenario with a Mission Critical Vocera System at One Site, and a Test System at Another

Summary	
Sites:	Multiple
Telephony Gateway Sharing:	No
PBX Failover:	Yes at Site A, No at Site B
High Availability:	Yes at Site A, No at Site B

Telephony High Availability

You can install multiple Vocera SIP Telephony Gateway servers —also called a telephony server array—at each site.

By installing an array of telephony servers at a site, you can take advantage of the following high availability features:

- **Redundancy** – If one of the telephony servers stops responding, the Vocera Voice Server automatically redirects outbound calls to another available telephony server for uninterrupted service.
- **Scalability** – You can purchase and install as many telephony servers as you need to increase telephony capacity.
- **Load balancing** – For outbound calls, the Vocera Voice Server automatically allocates calls to the least busy telephony server. The PBX equipment handles inbound load balancing.



Important: The Administration Console allows you to specify only one telephony configuration per site. If you deploy multiple telephony servers at one site, all of them must use the same configuration. Each telephony server installed at a site must use the same signaling protocol and have the same capacity. You can use telephony boards with different form factors (for example, PCI vs. PCI-X).

Generally, all telephony servers at a site will use the same PBX. However, they could use different PBXs as long as all PBXs have the same configuration for the trunks to the telephony servers and the same capabilities for off-PBX dialing (for example, tie lines).

Telephony servers in an array do not communicate with each other. Instead, the telephony servers respond to requests from the Vocera Voice Server. All communication with telephony servers is handled by the Vocera Voice Server.

Vocera SIP Telephony Gateway and PBX Failover Support

For PBX failover support, you can configure Vocera SIP Telephony Gateway to use multiple call signaling addresses.

On the *Telephony > Basic Info* page of the Administration Console, select the *Call Signaling Address* field and enter a comma-separated list of call signaling addresses for two or more IP PBXs or VoIP gateways. At startup, Vocera SIP Telephony Gateway tries each PBX or gateway in the order specified and uses the first one that responds. If that PBX or gateway goes down, Vocera SIP Telephony Gateway switches to another one.

The VSTG uses the response to a SIP OPTIONS message to determine if the PBX or gateway is currently available.

In some situations, using TCP as the signaling transport protocol reduces the length of time required for the VSTG to recognize that the current PBX is down and move to the next PBX in the list.

You can override the call signaling address for a particular Vocera SIP Telephony Gateway and have it connect to a different PBX than the one used by other Vocera SIP Telephony Gateway servers in the array.

For more information, see the *Vocera Voice Server Telephony Configuration Guide*.

Checklist for Preparing the Vocera SIP Telephony Gateway

Before you install Vocera SIP Telephony Gateway software, make sure the server computer itself is configured properly.

The table below provides a checklist that lists the tasks you should perform on your Vocera Voice Server system before using SIP Telephony.

<input type="checkbox"/>	<p>Log in to the Vocera SIP Telephony Gateway computer using an account with administrator privileges. This account should also use the default system locale, which was specified when Windows was installed on the computer.</p> <p>To view and change an account's locale settings, choose Start > Settings > Control Panel > Regional Options. For more information about locales, refer to your Windows documentation.</p>
<input type="checkbox"/>	<p>Make sure the Windows Installer service is enabled (see Enabling Windows Installer on page 40).</p>
<input type="checkbox"/>	<p>Make sure the Windows Update software does not apply updates automatically (see Configuring Windows Update on page 40).</p>

Preparing the Vocera Client Gateway

Learn about the Vocera Client Gateway architecture, the system requirements, and the tasks and procedures to perform before you install Vocera Client Gateway.

Vocera Client Gateway Architecture

Vocera Client Gateway supports Vocera smartphones, providing a signaling and multimedia gateway from the phones to the Vocera Voice Server for all calls.

Vocera Client Gateway also provides a tunnel for application data between the Vocera smartphone and the Vocera Voice Server. All communication between the Vocera Voice Server and the Vocera smartphone is done through the Vocera Client Gateway.

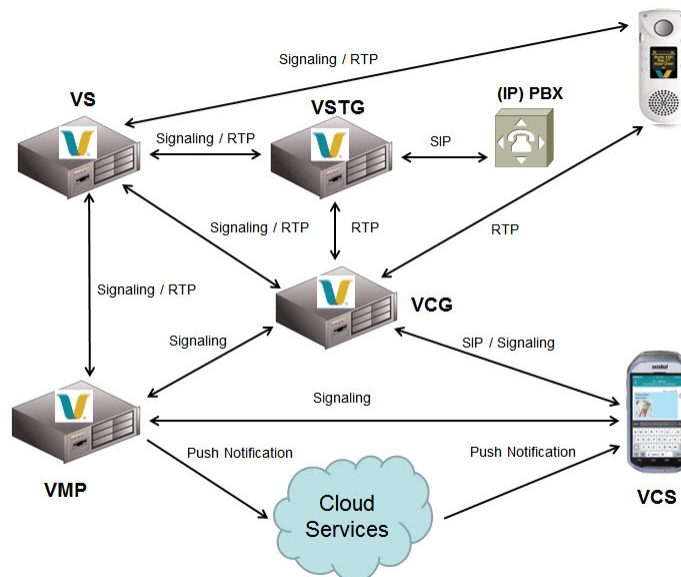

Figure 13: Vocera Client Gateway architecture

Location Service

Learn how the Vocera system locates client devices and smartphones on the network.

Vocera Client Gateway maintains a registry of Vocera smartphones, mapping their MAC addresses to call signaling addresses. A call signaling address is an IP address and port on which a device listens for SIP messages. The client devices or smartphone registers itself with the gateway when it boots up or changes its IP address due to subnet roaming. It also periodically registers with the gateway as a keep alive mechanism.

If you install multiple VCG servers (see [Installing Multiple Vocera Client Gateway Servers](#) on page 54), you can configure Vocera smartphones to support registration with multiple servers. Whenever the client device needs to register with a VCG (such as at boot-up or when the connection with the previously associated VCG fails), it randomly selects one of the VCG IP addresses from the complete list it has been configured with. If registration at that VCG fails, the smartphone randomly selects one of the remaining VCG IP addresses from the list. The smartphone attempts to connect to all of the VCGs in random fashion until it achieves a successful connection. If a successful connection is not achieved after trying the entire list of VCG servers, the smartphone will wait 10 seconds before beginning the registration process again.

Vocera Client Gateway Deployment Scenarios

With the high availability features provided for Vocera Client Gateway, there are several deployment scenarios to choose from based on whether your enterprise fully takes advantage of these features.

These factors include:

- number of Vocera sites
- capital budget limits

Single Site Scenarios

The simplest single site deployment scenario has one Vocera Voice Server connected to one VCG.

This scenario does not take advantage of any high availability features, such as redundancy and scalability.

Single Site Scenario with 1 VCG

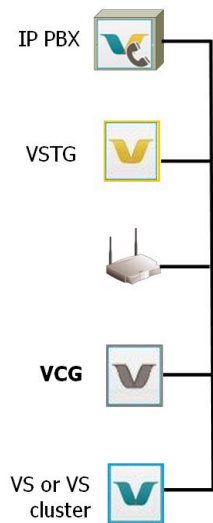

Summary	
Sites:	1
High Availability:	No

To add VCG high availability to a single site Vocera system, an array of VCG servers can be installed. This scenario provides redundancy and scalability.

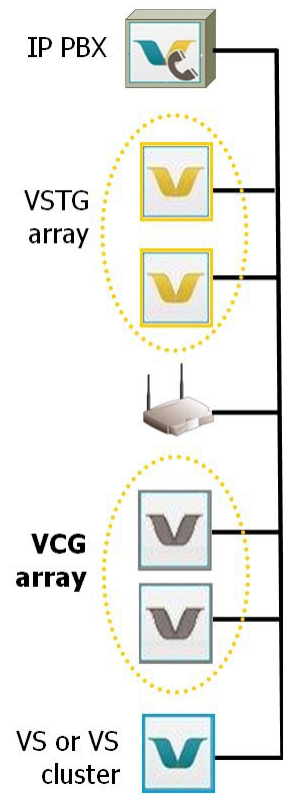

Figure 14: Single Site Scenario with a VCG Array

Summary	
Sites:	1
High Availability:	Yes

Multiple Site Scenarios

If your Vocera system has multiple sites, you can install a VCG at each site, or install multiple VCGs at each site for redundancy.

As long as you have multiple VCGs deployed, you can take advantage of high availability features.

The following multiple site scenario shows only one VCG installed at each site. This scenario lacks VCG redundancy unless smartphones are configured to connect to the VCGs at both sites.



Note: Vocera Voice Server version 4.4.3 and later support site-aware VCGs.

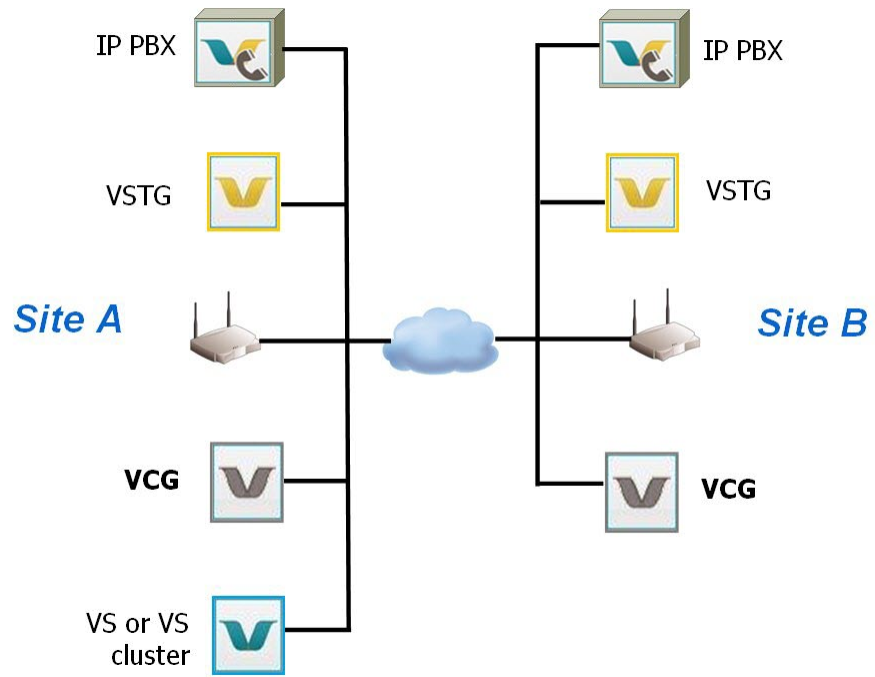

Figure 15: Multiple Site Scenario Using 1 VCG at Each Site

Summary	
Sites:	Multiple
High Availability:	No, unless smartphones are configured to connect to both VCGs across the WAN

The following multiple site scenario represents the best practice for high availability support. It has arrays of VCG servers installed at each site.

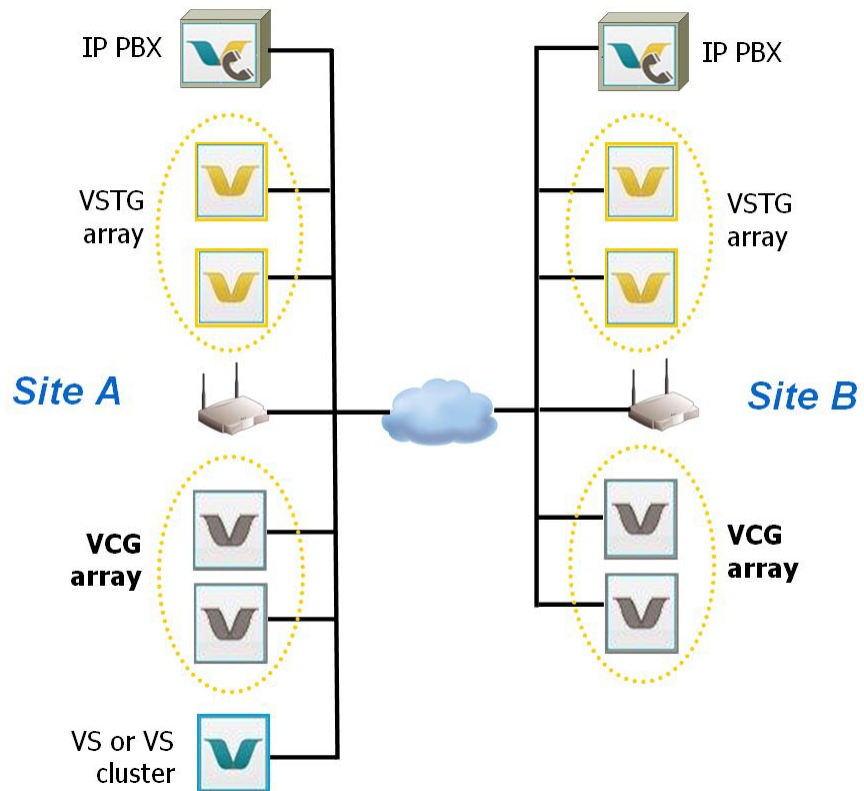

Figure 16: Multiple Site Scenario Using VCG Server Arrays

Summary	
Sites:	Multiple
High Availability:	Yes

Installing Multiple Vocera Client Gateway Servers

Learn the benefits of installing multiple gateways in your Vocera Voice Server environment.

You can install up to 4 Vocera Client Gateway servers for your Vocera system and take advantage of the following high availability features:

- **Redundancy** – If one of the VCG servers stops responding, Vocera smartphones automatically connect with another available VCG server for uninterrupted service.
- **Scalability** – You can install multiple VCG servers to increase smartphone calling capacity.

For more information about Vocera Client Gateway deployment scenarios, see [Vocera Client Gateway Deployment Scenarios](#) on page 51.



Important: Vocera recommends using the same configuration settings (specified in the `vgwproperties.txt` file) on each Vocera Client Gateway server in the array. This results in consistent settings for ports, logging, jitter buffer, and jitter tolerance. For more information about Vocera Client Gateway configuration, see the *Vocera Telephony Configuration Guide*.

Checklist for Preparing the Vocera Client Gateway

Learn the configurations task you should perform before you install the Client Gateway in your Vocera environment.

Before you install Vocera Client Gateway software, make sure the server computer itself is configured properly:

<input type="checkbox"/>	Log in to the Vocera Client Gateway computer using an account with administrator privileges. This account should also use the default system locale, which was specified when Windows was installed on the computer. To view and change an account's locale settings, choose <i>Start > Settings > Control Panel > Regional Options</i> . For more information about locales, refer to your Windows documentation.
<input type="checkbox"/>	Make sure the Windows Installer service is enabled (see Enabling Windows Installer on page 40).
<input type="checkbox"/>	Make sure the Windows Update software does not apply updates automatically (see Configuring Windows Update on page 40).

Preparing the Vocera Report Server

Learn about the system requirements and tasks to complete before you install the Vocera Report Server.

Preparing the Vocera Voice Server

Learn the needed tasks to perform before installing the Vocera Voice Server.



Important: If you are upgrading from an earlier version of the Vocera Report Server, see [Upgrading Vocera Report Server](#) on page 32 before you install the latest Vocera software.

Before you begin installing the Vocera Report Server software, perform the following task on the Vocera Voice Server (not the Vocera Report Server):

1. Upgrade the Vocera Voice Server to Version 5.2.3.
For upgrade instructions, see [Upgrading Vocera Voice Server Components](#) on page 31.
2. Start the Vocera Voice Server Administration Console and log in.
3. Click *System*.
4. On the *License Info* tab, enter the IP address of the Vocera Report Server in the *Report Server IP Address* field.

Preparing the Report Server

Learn the needed tasks to perform before installing the Vocera Report Server.

Before you install Vocera Report Server software, make sure the server computer itself is configured properly:

- Log in to the Vocera Report Server computer using an account with administrator privileges. This account should also use the default system locale, which was specified when Windows was installed on the computer. Otherwise, reports may not be formatted as designed. To view and change an account's locale settings, choose *Start > Settings > Control Panel > Regional Options*. For more information about locales, refer to your Windows documentation.
- Make sure the Windows Installer service is enabled (see [Enabling Windows Installer](#) on page 40).
- Make sure the Windows Update software does not apply updates automatically (see [Configuring Windows Update](#) on page 40).

Installing Vocera Voice Server Software

Learn how to install the Vocera Voice Server software

Running the Vocera Voice Installation Program

Follow these steps to install Vocera Voice Server in your environment.

Vocera Voice Server is distributed electronically using an ISO image file. Before installing and setting up Vocera Voice Server on your system, follow the steps in [Electronic Software Distribution](#) on page 12.



Note: If Vocera Secure Texting (VST) is installed in your environment, you must uninstall the VST Sync Connector *before* you upgrade to the latest version of Vocera Voice Server. See "How to Uninstall the Vocera Secure Texting Sync Connector" in the *VST Administrator Guide*. Re-install the Sync Connector after you complete the Vocera Voice Server upgrade. Make sure that you download and install the latest version of the VST Sync Connector.

Use the following steps to install Vocera Voice Server software components.

1. Log in to the computer with administrator privileges.
2. Locate and double click the Vocera Voice Server Suite Installer file.

A small icon of a file named 'VoceraSuiteInstaller.exe' with a blue and yellow logo to its left.

VoceraSuiteInstaller.exe

Figure 17: Vocera Suite Installer file

The Welcome window opens.

3. On the Welcome window, click Next to continue with the installation program.

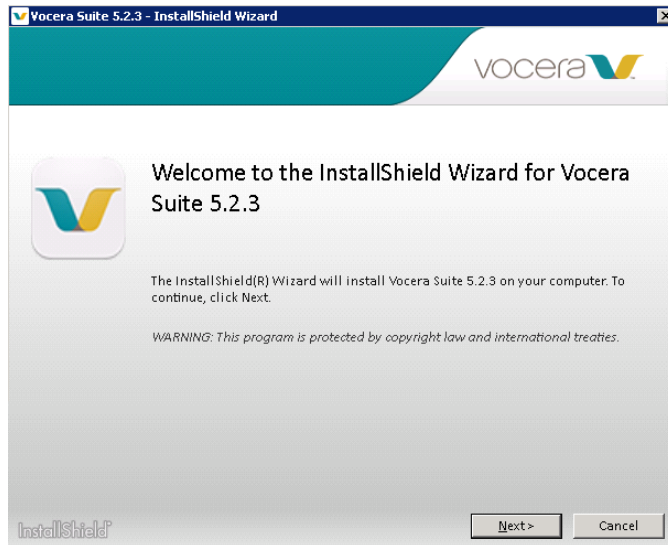

Figure 18: Welcome Window

The License Agreement window opens.

4. Review the license agreement before accepting the terms in the agreement and click Next.

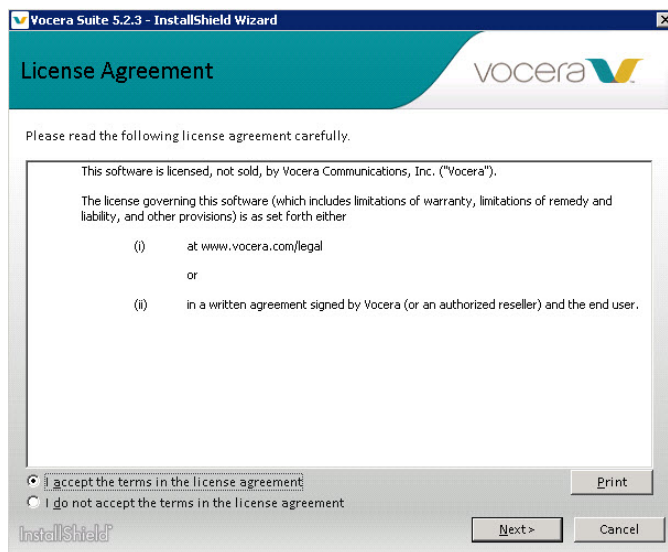

Figure 19: License Agreement Window

The Custom Setup Window opens.

5. In the Custom Setup window, select the radio button next to the feature that you want to install and click Next.

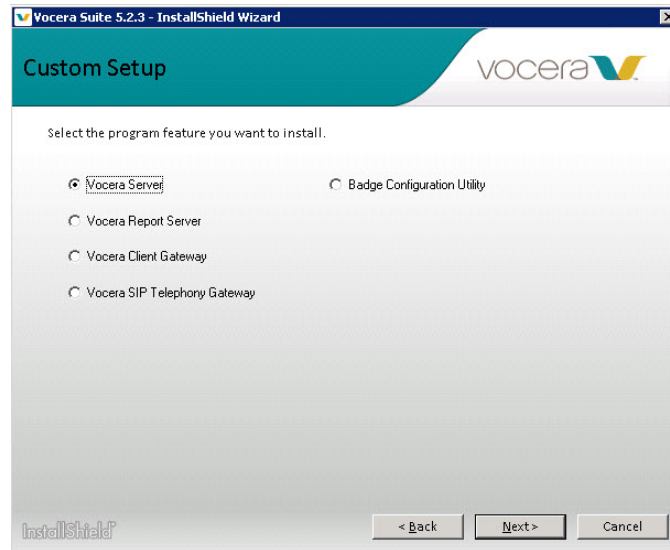

Figure 20: Custom Setup installation window

The Installation Configuration window opens.

6. In the installation configuration window, select the local IP address and the location for the drive where you want your Vocera Voice Server component installed. If needed, select the checkbox next to the SSL or the dual speech recognition setting and Click Next.

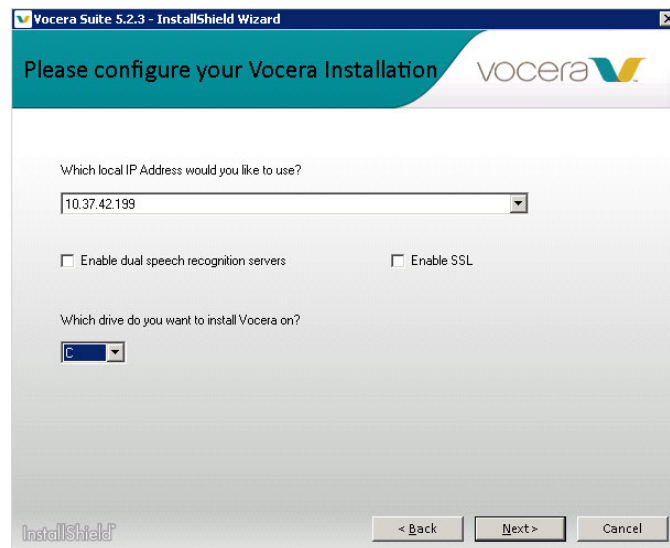

Figure 21: Installation Configuration window

For more information on Enable SSL and Enable dual speech recognition servers, see the *Vocera Server Administration Guide*.

The License File Location window opens.

7. There are two possible License File Location windows that can display based on the following:
 - If the installer detects an existing Vocera License: In the License File Location window, select the check box next to Use exiting License. Click Browse... to select the location for a different XML license file if desired.

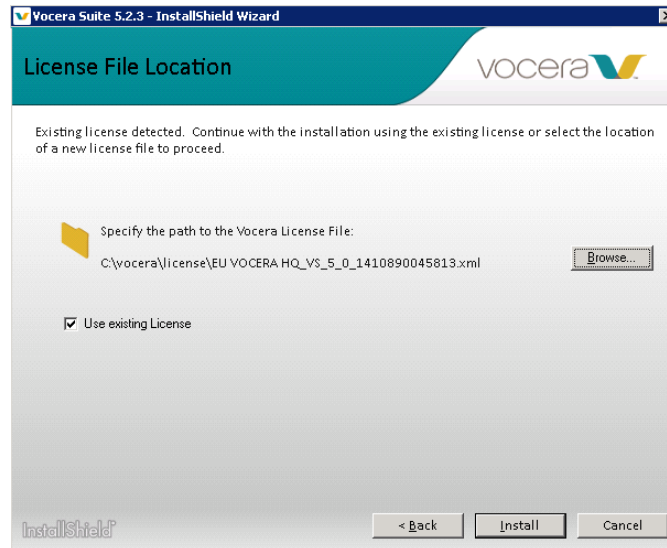

Figure 22: License File Location window (existing)

- If the installer does not detect an existing Vocera License: In the License File Location window, click Browse... to select the location for the XML license file that you obtained from Vocera Customer Support. If you do not have a Vocera license file, select the check box next to Install the License File Manually.

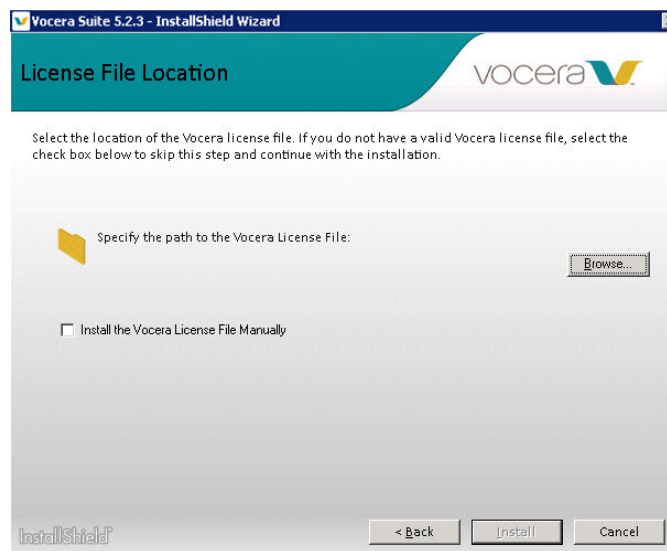

Figure 23: License File Location window



Note: If you do not have a license file, you can proceed with the installation using the installation program. However, you must install the Vocera Voice Server license file manually after the installation program completes since the Vocera Voice Server will not start unless the license file is present in the Vocera Voice Server license directory. See [Manually Installing the Vocera License File](#) on page 84 for more information.

The Vocera Voice Server installer is launched with a progress bar showing the status of the installation.

8. When the installation is finished, a window appears announcing that the installation is complete. Click Finish.

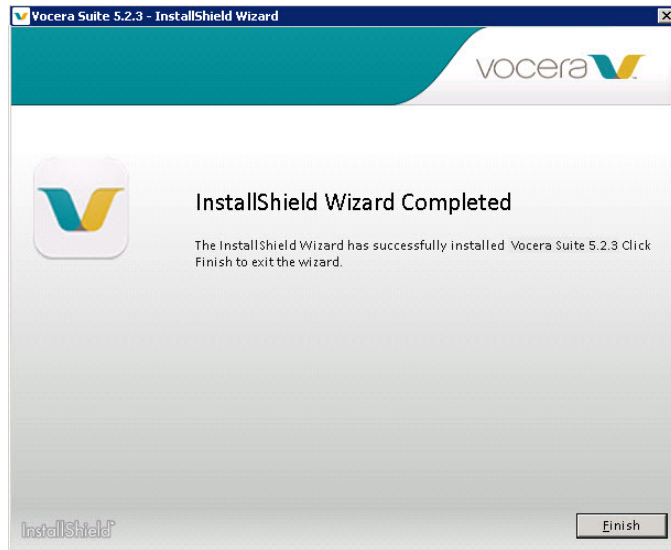

9. After the installation program completes, the installer opens a window where you can choose to restart your system.

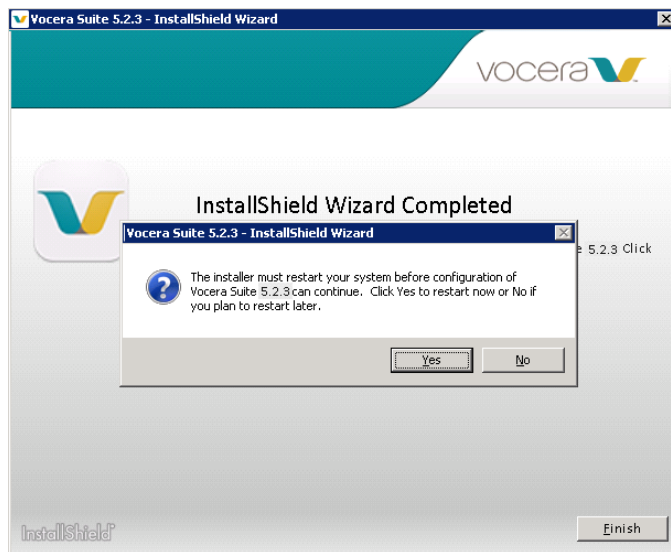

Figure 24: Vocera Restart Option Window



Note: After a new installation, you should restart the Vocera Voice Server before using Vocera. However, if you are performing this installation as part of an upgrade, DO NOT restart the server. Return to the upgrade tasks, and follow the steps in order.

10. If you did not install the Vocera Voice Server XML License file earlier, you must install the license file manually. See [Manually Installing the Vocera License File](#) on page 84.



Note: The Vocera Voice Server will not start unless the license key is installed.

Congratulations! Your installation is complete.

After you install Vocera Voice Server, you will need to set up Users and Groups. In addition, you may want to create a server cluster, or setup a staging server. For more information, see [Setting Up Users and Groups](#) on page 86, [Setting Up a Vocera Cluster](#) on page 77, and [Setting Up a Staging Server](#) on page 74.

Installing Vocera Voice Server Software Components

This section provides the steps needed to install the software for the following Vocera Voice Server software components.

Running the Vocera Client Gateway Installation Program

Follow these steps to install Vocera Client Gateway (VCG) in your environment.

Vocera software is distributed electronically using an ISO image file. Before installing and setting up Vocera on your system, follow the steps in [Electronic Software Distribution](#) on page 12.

Use the following steps to install Vocera Voice Server software components.

1. Log in to the computer with administrator privileges.
2. Locate and double click the Vocera Voice Server Suite Installer file.

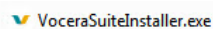

Figure 25: Vocera Suite Installer file

The Welcome window opens.

3. On the Welcome window, click Next to continue with the installation program.



Figure 26: Welcome Window

The License Agreement window opens.

4. Review the license agreement before accepting the terms in the agreement and click Next.

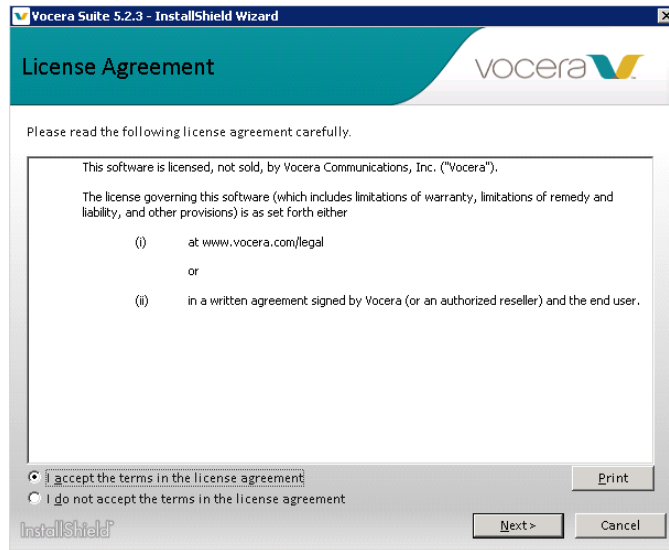

Figure 27: License Agreement Window

The Custom Setup Window opens.

5. In the Custom Setup window, select the radio button next to the feature that you want to install and click Next.

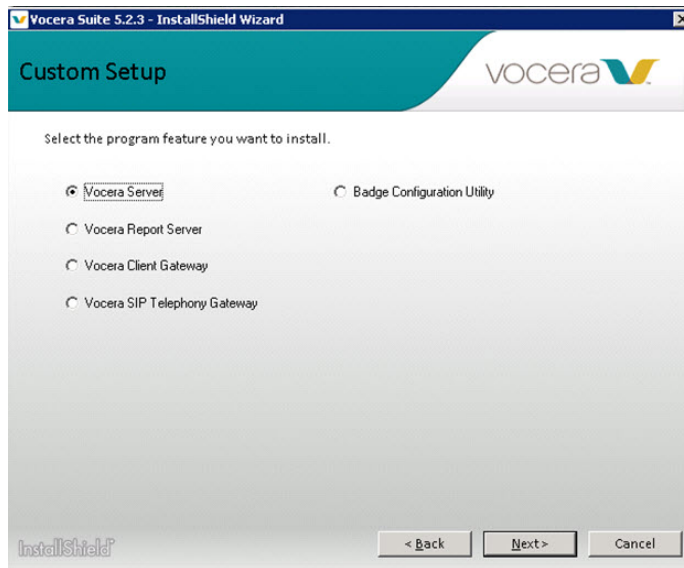

Figure 28: Custom Setup installation window

An Installation configuration window opens.

6. In the installation configuration window, select the local IP address where Vocera Client Gateway server will be installed, and the location for the drive where you want VCG installed. Click Next.

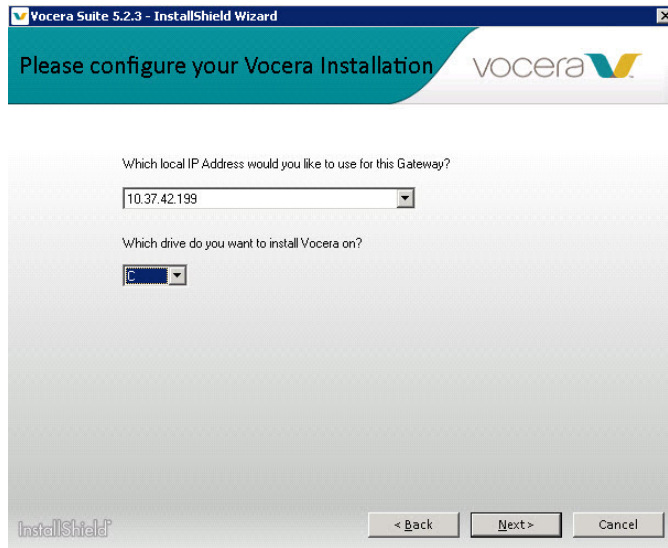

Figure 29: Installation Configuration window

An additional Vocera Voice Server configuration window opens.

7. In the next installation configuration window, select the IP address for the Vocera Voice Server (to ensure communication between VS and VCS), and the Telephony site name. Click Next.

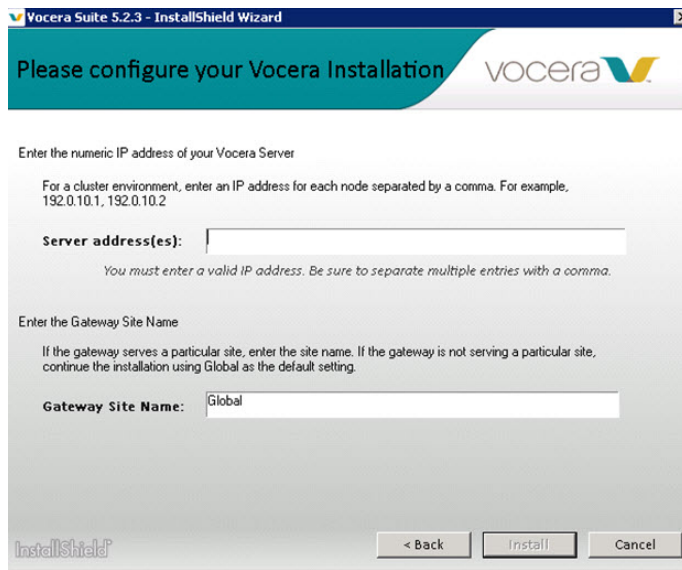
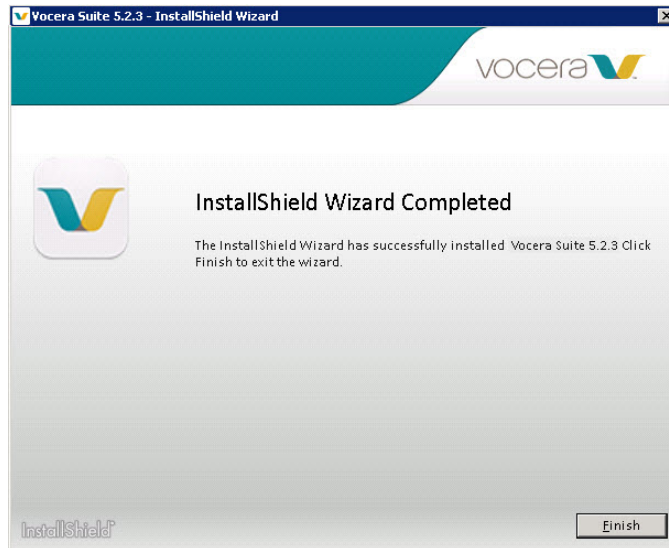

Figure 30: Installation Configuration window

The Vocera Voice Server installer is launched with a progress bar showing the status of the installation.

8. When the installation is finished, a window appears announcing that the installation is complete. Click Finish.



Congratulations! Your installation is complete.

Running the Vocera Report Server Installation Program

Follow these steps to install Vocera Report Server(VRS) in your environment.

Vocera software is distributed electronically using an ISO image file. Before installing and setting up Vocera Voice Server on your system, follow the steps in [Electronic Software Distribution](#) on page 12.

Use the following steps to install Vocera software components.

1. Log in to the computer with administrator privileges.
2. Locate and double click the Vocera Suite Installer file.

 VoceraSuiteInstaller.exe

Figure 31: Vocera Suite Installer file

The Welcome window opens.

3. On the Welcome window, click Next to continue with the installation program.

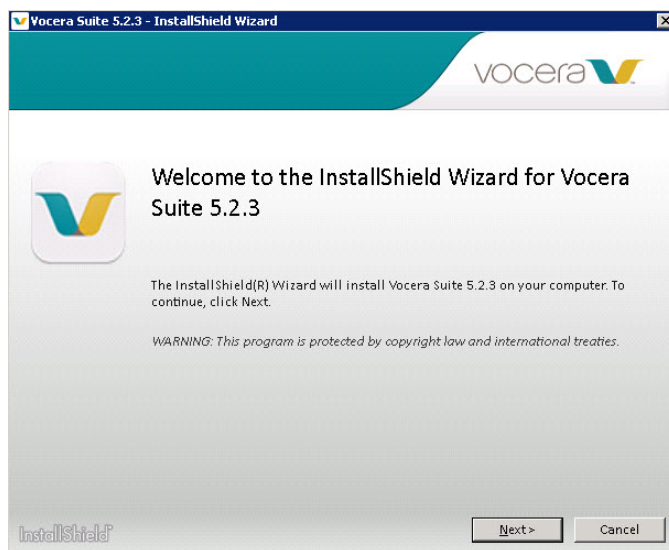

Figure 32: Welcome Window

The License Agreement window opens.

4. Review the license agreement before accepting the terms in the agreement and click Next.

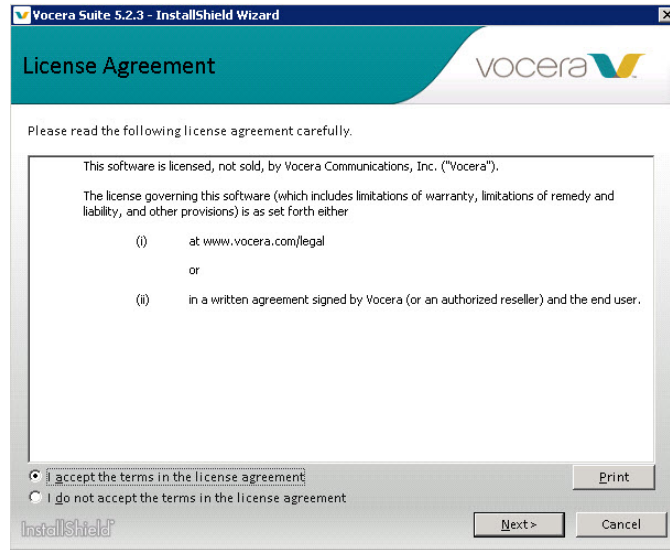

Figure 33: License Agreement Window

The Custom Setup Window opens.

5. In the Custom Setup window, select the radio button next to the feature that you want to install and click Next.

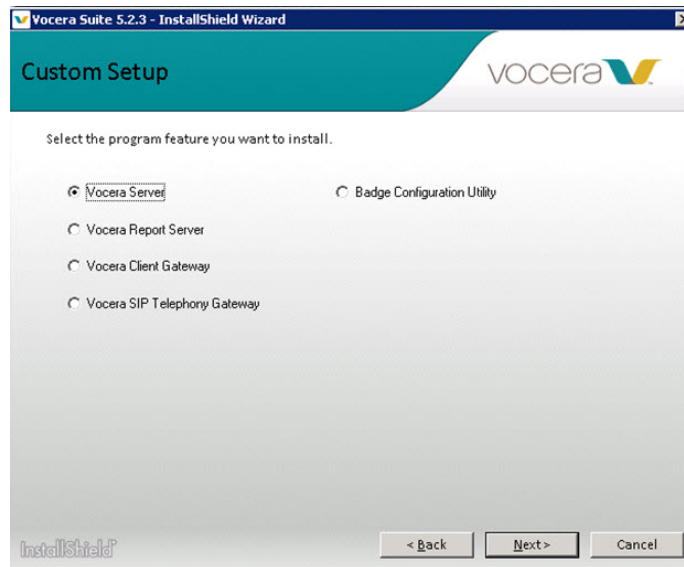

Figure 34: Custom Setup installation window

The License File Location window opens.

6. In the License File Location window, click Browse... to select the location for the XML license file that you obtained from Vocera Customer Support. If you do not have a Vocera Voice Server license file, select the check box next to Install the License File Manually. Click Next.

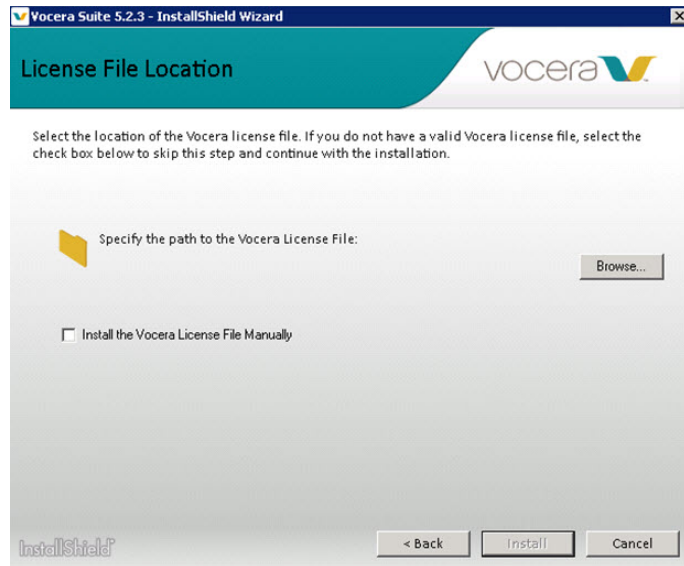

Figure 35: License File Location window



Note: You can proceed with the installation using the installation program even if you do not have a Vocera license file. However, you must install the Vocera Voice Server license file manually after the installation program completes since the Vocera Voice Server will not start unless the license file is present in the Vocera license directory. See [Manually Installing the Vocera License File](#) on page 84 for more information.

A window opens where you can locate and select the XML license file.

7. Browse and locate the XML license file and click Open.

When you select the XML license file, the Installation Program:

- Creates the Vocera license directory
- Copies the XML license file into the Vocera Voice Server license directory

After the Installation Program completes this process, an installation configuration window opens.

8. In the installation configuration window, select the local IP address for your VRS installation, the SSL setting, and the location for the drive where you want your Vocera component installed. Click Next.

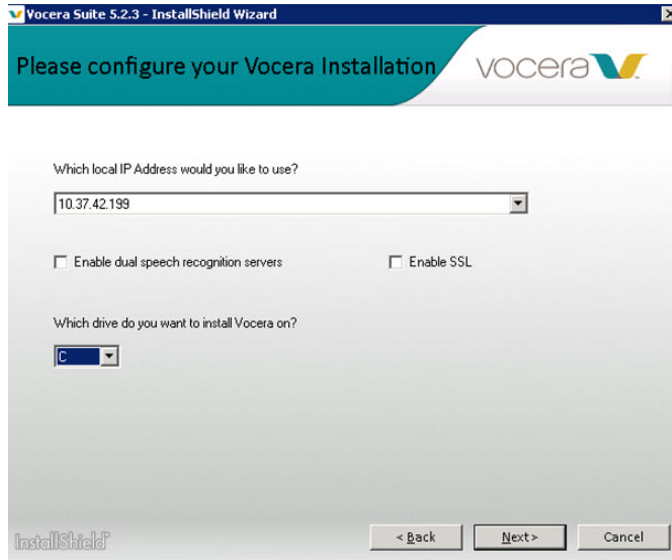

Figure 36: Installation Configuration window

An additional installation configuration window opens where you specify the location of the Vocera Voice Server.

9. In the next installation configuration window, select the IP address for your Vocera Voice Server installation to ensure that Vocera Report Server connects to the Vocera Voice Server. Click Next.

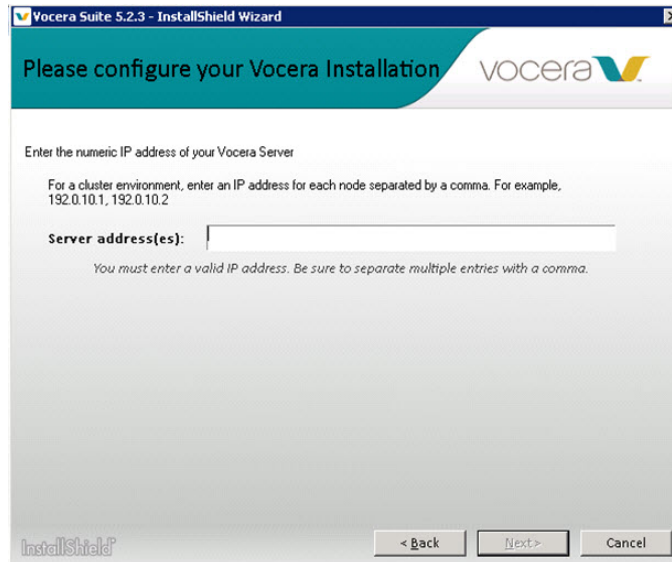
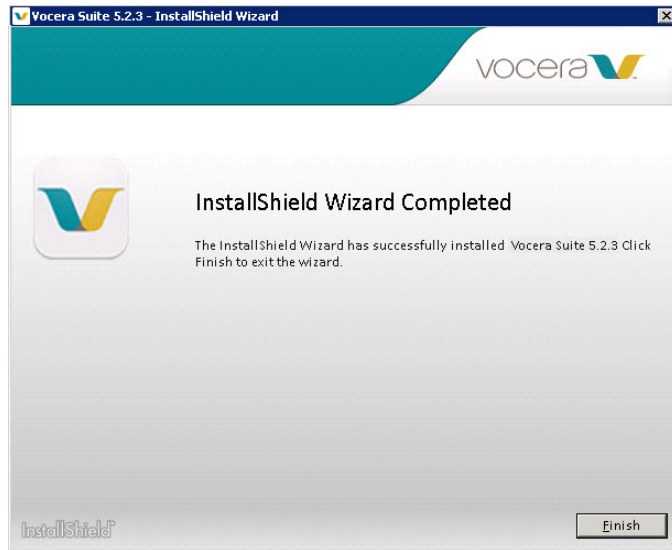

Figure 37: Installation Configuration window

The Vocera installer is launched with a progress bar showing the status of the installation.

10. When the installation is finished, a window appears announcing that the installation is complete. Click Finish.



11. After the installation program completes, the installer opens a window where you can choose to restart your system.



Figure 38: Vocera Restart Option Window

Note: After a new installation, you should restart the Vocera Voice Server before using Vocera Report Server.

12. If you did not install the Vocera XML License file earlier, you must install the license file manually. See [Manually Installing the Vocera License File](#) on page 84.

Note: The Vocera Voice Server will not start unless the license key is installed.

Congratulations! Your installation is complete.

Running the Vocera SIP Telephony Gateway Installation Program

Follow these steps to install Vocera SIP Telephony Gateway (VSTG) in your environment.

Vocera Voice Server software is distributed electronically using an ISO image file. Before installing and setting up Vocera on your system, follow the steps in [Electronic Software Distribution](#) on page 12.

Use the following steps to install Vocera Voice Server software components.

1. Log in to the computer with administrator privileges.
2. Locate and double click the Vocera Suite Installer file.



Figure 39: Vocera Suite Installer file

The Welcome window opens.

3. On the Welcome window, click Next to continue with the installation program.

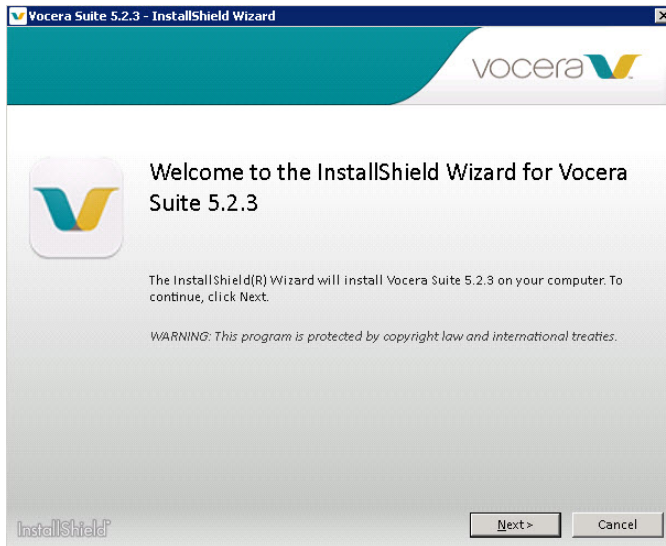

Figure 40: Welcome Window

The License Agreement window opens.

4. Review the license agreement before accepting the terms in the agreement and click Next.

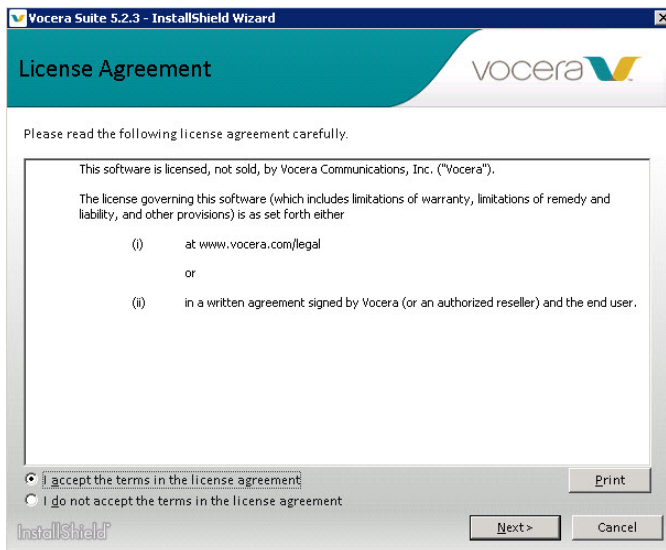

Figure 41: License Agreement Window

The Custom Setup Window opens.

- In the Custom Setup window, select the radio button next to the feature that you want to install and click Next.

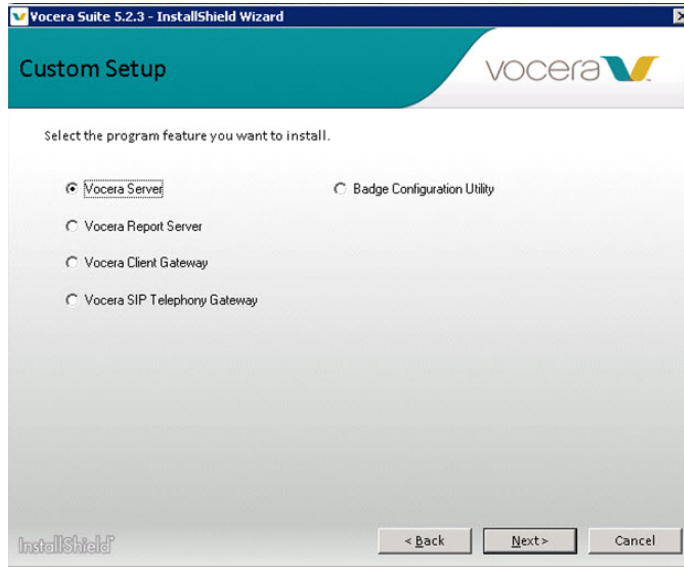

Figure 42: Custom Setup installation window

The Installation configuration window opens.

- In the installation configuration window, select the local IP address where Vocera SIP Telephony Gateway server will be installed, and the location for the drive where you want VSTG installed. Click Next.

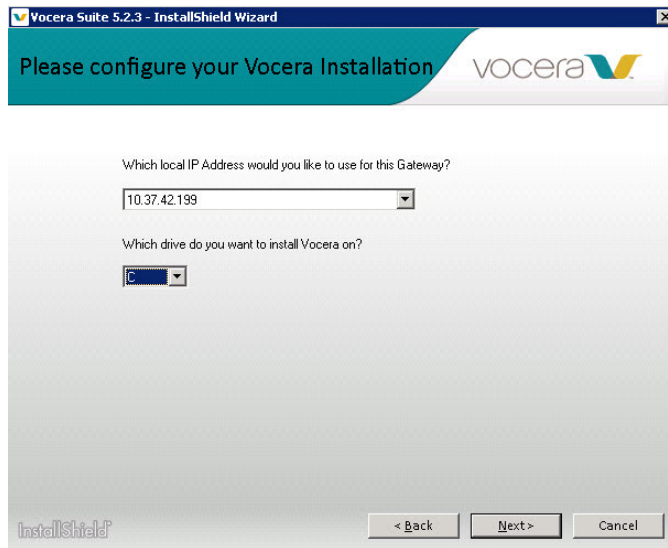

Figure 43: Installation Configuration window

An additional Vocera configuration window opens.

- In the next installation configuration window, select the IP address for the Vocera Voice Server (to ensure communication between VSTG and VS), and the Telephony site name. Click Next.

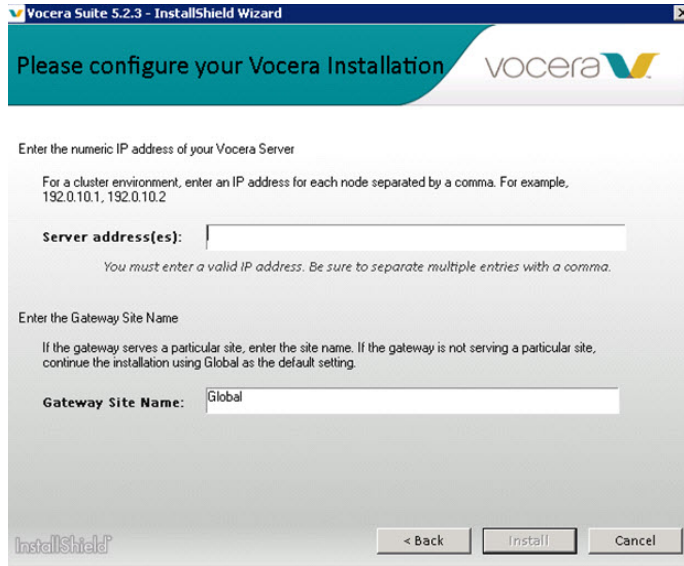
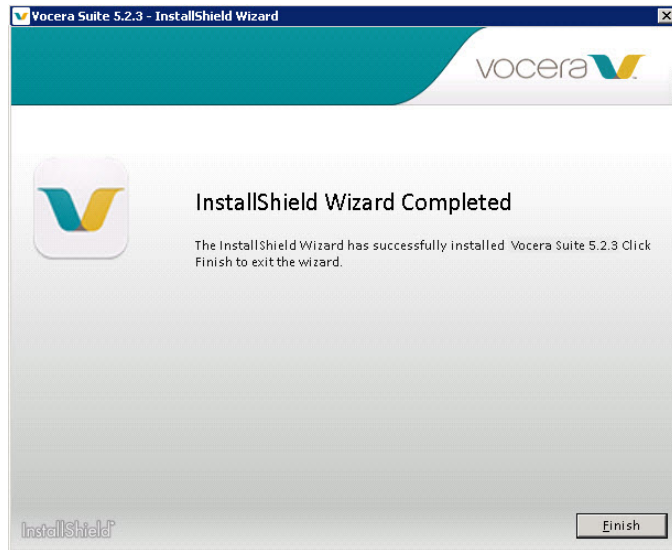

Figure 44: Installation Configuration window

The Vocera installer is launched with a progress bar showing the status of the installation.

8. When the installation is finished, a window appears announcing that the installation is complete. Click Finish.



Congratulations! Your installation is complete.

Uninstalling Vocera Voice Server Software

Learn how to remove Vocera Voice Server software from your server.

Prerequisite: For VSTG and VCG software removal, be sure to stop the VSTG or VCG server before running the application to remove Vocera. For VRS, stop Tomcat services.

Vocera Voice Server provides an easy way to remove Vocera products from your server utilizing the Windows control panel utility which launches the Vocera uninstaller application.

When you uninstall the Vocera Voice Server server, Vocera Client Gateway Server, Vocera SIP Telephony Gateway Server, and the Vocera Report Server the installation program removes most of the files in the \vocera directory and other directories. The installation program server uses the remaining files when you reinstall or upgrade your system.



Important: If you are planning to reinstall or upgrade Vocera on your system, **do not** remove the remaining Vocera files since they are needed for subsequent Vocera installations and upgrades.

To remove Vocera Voice Server software for all components:

1. Log into the computer with administrator privileges.
2. For Vocera Voice Server and Vocera Report Server only: If you are removing the Vocera Voice Server, back up your data.
For more information see [Backing up Vocera Data](#) on page 30.
3. If the Vocera Voice Server is running, shut it down.
For more information see [Shutting Down the Vocera Voice Server Server](#) on page 94.
4. For **Windows 2008** and **Windows 2012**, follow these steps:
 - a. Open the Windows Control Panel and select Programs and Features
 - b. Locate and select Vocera Suite. The Vocera uninstaller is launched and displays the Remove the Program window.

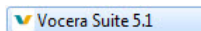

Figure 45: Vocera Suite



Note: Earlier versions of Vocera do not have Vocera Suite available. To remove earlier versions of Vocera products, in Programs and Features locate the Vocera product from the list of installed programs and select Remove.

5. From the Remove the Program window, click Remove. A new window opens that shows the status of the software removal wizard.
6. When finished, select Yes, I want to restart my computer now, and click Finish.

Post-Installation Configuration

Learn the recommended and additional configuration and setup tasks for Vocera Voice Server.

- [Setting Up a Staging Server](#) on page 74
- [Setting Up a Vocera Cluster](#) on page 77
- [Manually Installing the Vocera License File](#) on page 84
- [Setting Up Users and Groups](#) on page 86



Setting Up a Staging Server

For mission critical deployments of the Vocera Voice Server, Vocera recommends setting up a staging server to test software and database changes to validate whether they work in your environment before updating your production server.

If you purchase a Vocera Enterprise License, Vocera includes an additional 6-seat Enterprise License that can be used to test the server.

A Vocera staging server is excellent for:

- Testing a software upgrade or update
- Learning how to use new features
- Developing a training plan for new features
- Testing badge property network changes
- Testing major database changes to your system
- Testing call flows and forwarding conditions
- Estimating the downtime needed to perform the upgrade on your production system

A Vocera staging server is NOT appropriate for:

- Infrastructure testing
- Stress testing
- Testing telephony integration
- Testing roaming (unless the staging server connects to the same VLAN as the production server)
- Testing cluster failover
- Moving data back and forth between the staging and production server

Staging Server Network Architecture

Learn the recommended network architecture that you should use when setting up the Vocera staging server.

When you set up your staging server, choose from the following network architectures:

- **Connect to a Standalone AP** – The staging server is connected to its own wireless access point with its own SSID.

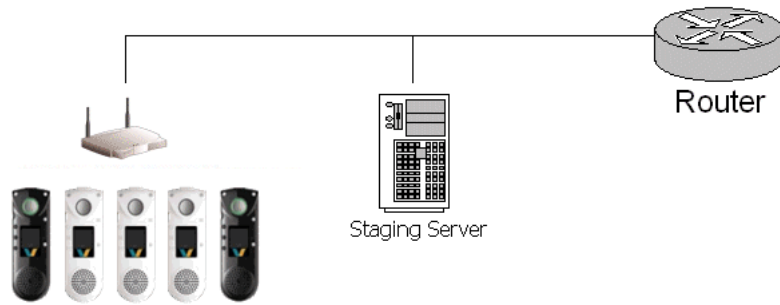

Figure 46: Staging Server with Standalone AP

- Connect to the Production VLAN – The staging server is connected to the production VLAN using either the same SSID as the production VLAN or a new SSID.

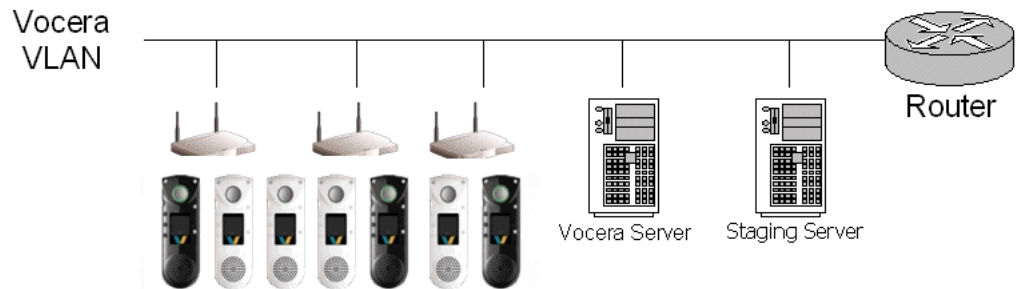

Figure 47: Staging Server connected to Production VLAN

- Connect to a Testing VLAN – The staging server is connected to a testing VLAN using either the same SSID as the production VLAN or a new SSID.

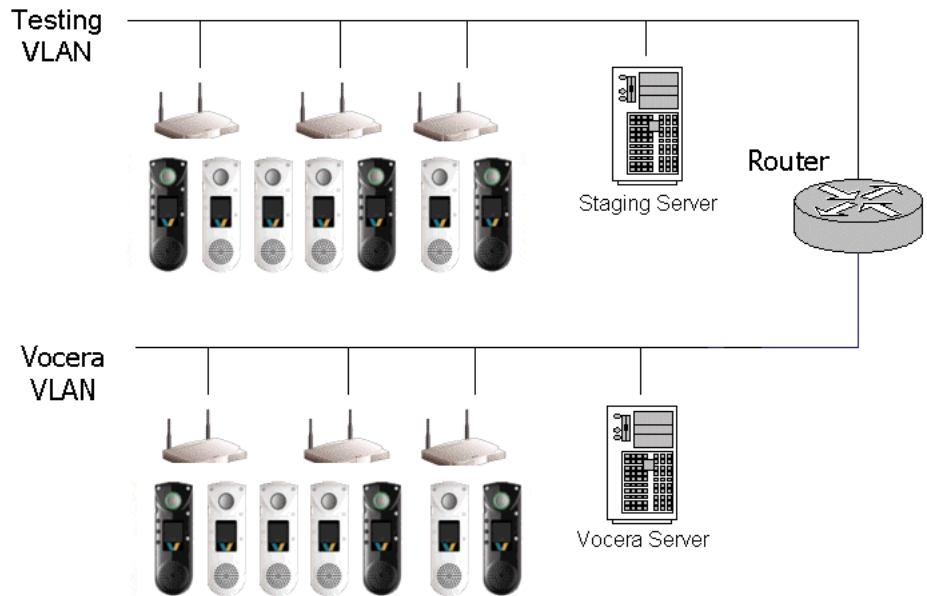

Figure 48: Staging Server connected to Testing VLAN

Configuring Badges to Connect to the Staging Server

This section provides a quick summary on how to configure badges to connect to the Vocera Voice Server staging server.

To test the Vocera Voice Server staging server, you should configure several badges to connect to it. Try to make badge-to-badge calls and test other Vocera functionality.

For complete instructions, see the *Vocera Badge Configuration Guide*.

1. On the configuration computer, back up the **badge.properties** file located in the **\vocera\config** directory. Name the backup copy **badge.properties.production**. This file contains badge properties used for your Vocera production server.
2. Use the Badge Properties Editor on the configuration computer to set the *Vocera Server IP Address* property to the IP address of the Vocera Voice Server staging server.
3. Copy the **badge.properties** file from the configuration computer to the Vocera Voice Server staging server.
4. Restore factory settings on the badges you want to use to test the Vocera staging server.
5. Put fully charged batteries in two badges.
6. Start the Badge Configuration Utility on the Vocera Voice Server configuration computer.
7. Make sure the badges connect to the Vocera Voice Server staging server.
8. If the badges are unable to connect to the Vocera Voice Server staging server or make and receive calls, repeat steps 2 through 6 to make any needed changes to badge properties.
9. On the configuration computer, restore the badge properties for your Vocera Voice Server production server. Rename the **badge.properties** file located in the **\vocera\config** directory to **badge.properties.staging**. Then rename the **badge.properties.production** file to **badge.properties**.

After you have validated that the Vocera Voice Server staging server works properly, you can follow the instructions to install or upgrade the Vocera Voice Server production server.

When the Vocera production server is ready, you can change the **Vocera Voice Server IP Address** property of the test badges to the IP address of the Vocera production server. If the production server is a cluster, enter the IP address of each machine in the cluster, separated by commas, with no spaces.



Setting Up a Vocera Cluster

Learn how to set up and control a Vocera cluster.

About Vocera Voice Server Clusters

Learn concepts related to Vocera Voice Server clusters.

Some environments require redundancy to support critical applications in the event of hardware or software failure. In such environments, a critical application is installed on two or more computers. The computer controlling the application is called the *active* node, and the other computers are called the *standby* nodes. This redundant combination of active and standby nodes is called a *cluster*.

Vocera clustering provides high availability when any of the following events occur:

- The computer hardware fails.
- The Vocera Voice Server fails.
- The Nuance service fails.
- The MySQL service fails.

The cluster's active node controls the Vocera system, but a standby node can take over control of the application if the active node fails. The situation where a standby node takes control from the active node is called a *failover*.

The telephony integration option (Vocera SIP Telephony Gateway, if installed, should run on a server that is separate from the Vocera cluster so telephony support can continue if the Vocera Voice Server fails over. Failover for the telephony server itself is supported as part of the high availability architecture.

The following figure shows the way that the Vocera SIP Telephony Gateway, the Vocera Report Server, and badges connect to a Vocera cluster:

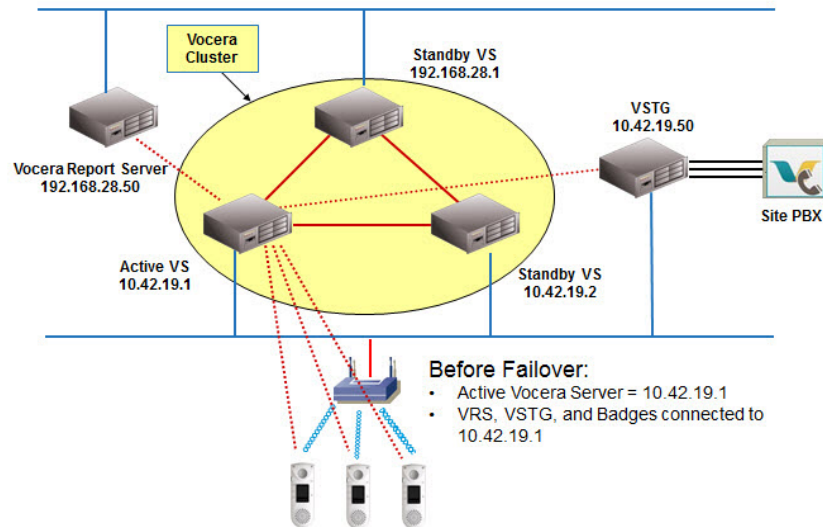

Figure 49: Vocera Cluster Before Failover

As shown in the above illustration, the nodes in a Vocera cluster do not share a single virtual IP address, as they would with the Microsoft Cluster Service. Instead, the badges, the Vocera SIP Telephony Gateway, and the Vocera Report Server are all associated with **10.42.19.1**, the IP address of the *active* Vocera Voice Server. Similarly, any Administration Console or User Console sessions would also point to the IP address of the active Vocera Voice Server.

Vocera supports a maximum of four cluster nodes (one active node and three standby nodes). Each cluster node maintains its own copy of the Vocera database, the Vocera Report Server log files, and the `badge.properties` file. The cluster synchronizes these files continually.

If a failover occurs, one of the standby nodes becomes active and takes control of the cluster. At that time, the badges, the Vocera SIP Telephony Gateway, and the Vocera Report Server automatically associate with the IP address of the newly active node, as shown in the following illustration:

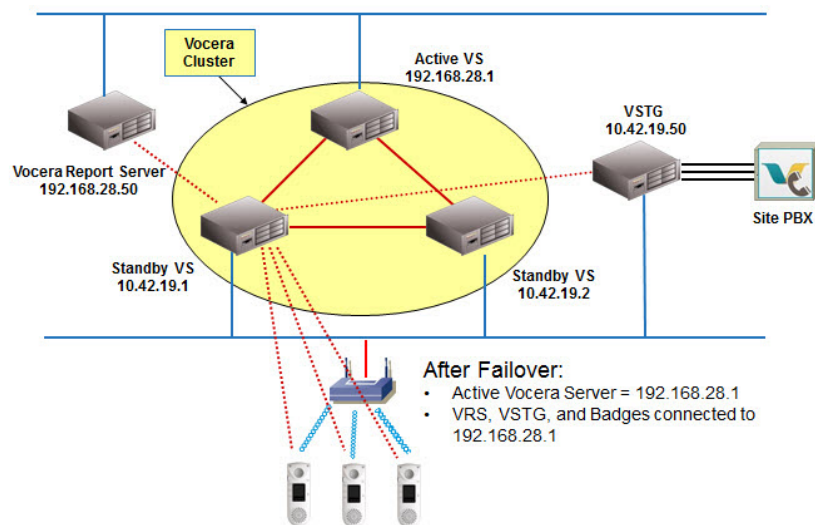

Figure 50: Vocera Cluster After Failover

As shown in the above illustration, Vocera Voice Server nodes, the Vocera SIP Telephony Gateway, and the Vocera Report Server can reside on different subnets. In a Vocera cluster, the Vocera Voice Server and all its related services are always running on any standby nodes so failover can occur quickly. If the active node fails, a standby node becomes active and takes control of the cluster almost immediately.

You can use the Administration Console or the Vocera Control Panel to determine which node of a cluster is active:

- The Vocera Control Panel displays a status message to indicate whether its server is in active or standby mode.
See "Determining the Status of a Server" in the *Vocera Installation Guide* for complete information.
- The *Address* field of your web browser displays the IP address of the active Vocera Voice Server.

Because each node maintains an independent copy of the database, the Vocera cluster architecture allows disaster survival. The use of multiple nodes will also allow rolling upgrades with minimal down-time in the future.

Setting Up an Initial Cluster Configuration

The following procedure summarizes the steps in an initial Vocera Voice Server cluster configuration.

1. Install all the software and hardware as follows:
 - a. Perform the preinstallation tasks described in [Preparing the Vocera Voice Server](#) on page 39.
 - b. Install the Vocera Voice Server on every computer that will be a member of the cluster.
If necessary, you can also add and remove servers any time after the setup is complete.
 - c. If you are using the telephony integration option, install the Vocera SIP Telephony Gateway software.
 - d. If you are planning to use the Vocera Report Server, install it also.
2. On the computer(s) that will be the standby node(s), use the Vocera Control Panel to stop the Vocera Voice Server.



Important: Keep the Vocera Voice Server on the standby nodes stopped while you configure the active node. This ensures that when you start the standby nodes they will perform a remote restore from the active node because it has been running longer. Otherwise, you may unintentionally cause the active node to perform a remote restore from one of the standby nodes.

3. Prepare the Vocera Voice Server that you want to use as the initial active node as follows:
 - a. On the Vocera Voice Server that you want to use as the initial active node, fully configure the database or restore an existing database.
See the *Vocera Administration Guide* for information about setting up users and groups and restoring data from a backup file.
 - b. If you did not restore from a backup file, back up the database on the initial active node. Although this step is not required, best practice is to do a complete backup to preserve your work in case you need to rollback to it.
 - c. On your configuration computer, create a **badge.properties** file that includes the IP address of every machine in your cluster in a comma-separated list.
See the *Vocera Badge Configuration Guide*.
 - d. Copy the new **badge.properties** file to the `\vocera\config\` directory of the initial active node.
The standby nodes copy this file when they come online as cluster members. See the *Vocera Voice Server Administration Console Guide*.

- e. If you have a customized **Properties.txt** file, make sure you copy it to the **\vocera\server** directory on every Vocera Voice Server.
 - f. Restart the Vocera Voice Server on the machine you want to use as the initial active node so it loads your new **Properties.txt** file and **badge.properties** file.
4. Set up clustering on the server that you want to use as the initial active node.
 - a. Log in to the Administration Console of the Vocera Voice Server you want to use as the initial active node.
 - b. Click **System** in the navigation bar.
 - c. Click the **Cluster** tab to display the Cluster Setup page.
The IP address of the current server appears in the server list. The **Status** column displays "Unsaved".
 - d. Check **Enable Cluster**.
The buttons for setting up and maintaining the cluster appear to the right of the server list.
 - e. Click **Add Server**.
The Add/Edit Cluster Server dialog box appears. Use this dialog box to add servers to a cluster.
 - f. Enter the IP address of a standby server and a brief description, and then do either of the following:
 - If you do not need to add other nodes to the cluster, click **Add** to save changes, close the Add/Edit Cluster Server dialog box, and display the Cluster Setup page.
 - If you need to add any other nodes to the cluster, click **Add & Continue** to save the information and leave the Add/Edit Cluster Server dialog box open, then add another node.

When you are finished, the server list displays the IP address of each server you added along with any descriptions you entered. The **Status** column for each new server displays "Unsaved".
 - g. Click **Save Changes**.
Vocera saves the information and displays the first tab of the System screen, License Info.
 - h. Click the **Cluster** tab to display the Cluster Setup page and check your work. The server list should display the following:
 - The **Status** column for the current server displays "Active".
 - The **Status** column for each additional server displays "Unknown".

The cluster discovers the status of these unknown servers after you configure them for clustering and restart them.
 - i. Click the **Log Out** button at the top of the page.
The system logs you out and displays the Log In page of the Administration Console.
 5. On the standby node(s), use the Vocera Control Panel to start the Vocera Voice Server.
 6. Set up clustering on every other server that will be in the cluster. These additional servers will become standby nodes in the cluster.
 - a. Log in to the Administration Console of a server you want to use as a standby node.
 - b. Click **System** in the navigation bar.
 - c. Click the **Cluster** tab to display the Cluster Setup page.
The IP address of the current server appears in the server list. The **Status** column displays "Unsaved".
 - d. Check **Enable Cluster**.
The buttons for setting up and maintaining the cluster appear to the right of the server list.
 - e. Click **Add Server**.
The Add/Edit Cluster Server dialog box appears. Use this dialog box to identify the server you are using as the initial *active* server.

- f. Enter the IP address of the active server and a brief description, and then click the **Add** button to save changes, close the **Add/Edit Cluster Server** dialog box, and display the **Cluster Setup** page.



Note: You do not have to add the IP address of any other cluster servers to the list. When you restart the server you are configuring, it will download this information from the active server.

- g. Click **Save Changes**.
Vocera saves the information and displays the first tab of the **System** screen, **License Info**.
- h. Click the **Cluster** tab to display the **Cluster Setup** page. The server list should display the following:

- The **Status** column for the current server displays “Active”.
- The **Status** column for the server you want to use as the initial active server displays “Unknown”.

- i. Click **Force Restart**.
A dialog box asks you to confirm restarting the server.



Note: If you do not click **Force Restart**, within a minute the cluster’s self-healing mechanism will cause the server to automatically enter discovery mode, perform a remote restore from the active server, and then come online as a standby node.

- j. Click **OK**.
Vocera logs you out of the current server’s **Administration Console**, and the current server restarts as a standby node in the cluster. If you copied a customized **Properties.txt** file to each standby, the Vocera Voice Server loads it when it restarts.



Note: You cannot log in to the **Administration Console** of a server after it becomes a standby node. If you attempt to log in to a standby node’s **Administration Console**, the cluster redirects you to the **Administration Console** of the active node.

7. If you use the telephony integration option, open the Vocera SIP Telephony Gateway control panel and set the **Server IP Address** field to the IP address of the *active* Vocera Voice Server. After you save this setting, the Vocera Voice Server populates the **Server IP Address** field with a comma-separated list of all cluster IP addresses. The Vocera Voice Server maintains this list if cluster nodes are added or removed.



Note: You can optionally enter a comma-separated list of all cluster IP addresses manually in the **Server IP Address** field.

8. If you use a Vocera Report Server, open the **Report Console** and enter a comma-separated list of all cluster IP addresses in the **Vocera Voice Server IP Address** field.
Because the Vocera Report Server does not communicate continually with the Vocera Voice Server, you must enter every cluster IP address. The Vocera Report Server does not maintain this list of addresses.
9. Check your work.
 - a. Log in to the **Administration Console** of the active Vocera Voice Server. Make sure each server shows up in the list on the **Cluster Setup** page with the proper status of “active” or “standby”.
 - b. Fail over cluster control several times, until you confirm that the cluster behaves as you expect. For more information see [Forcing a Failover](#) on page 82.

Controlling a Cluster

In some situations, you may want to intervene manually and take control of one or more servers. However, in most situations, the active node of a cluster runs continually while the standby nodes wait in case a failure occurs.

Forcing a Failover

Follow these steps in order to force a failover when needed.

A *failover* occurs when the active node passes control of a cluster to one of the other nodes. Failure of either the Vocera Voice Server on the active node or its hardware results in a failover.

In some situations, however, you may want to *force* a failover to occur. For example, you may want to initiate a failover so you can perform planned maintenance on the active node, or to test your cluster set up.

Use the Vocera Control Panel or the Administration Console of the active node to force a failover. See [Using the Vocera Control Panel](#) on page 90 for additional information.

Use the following steps to initiate a failover through the Vocera Control Panel:

1. Display the Vocera Control Panel on the *active* node of the cluster.
2. Choose **Failover** from the **Cluster** menu of the Vocera Control Panel.
A dialog box asks you to confirm the failover.
3. Click **OK**.
Control of the cluster fails over and a new node becomes active and takes control of the cluster almost immediately.

Restarting a Standby Node

Follow these steps to restart a standby node.

You can restart a standby node at any time without affecting the cluster. You must use the Vocera Control Panel to restart a standby node, because the Administration Console for a cluster provides access to the active node only.



Note: You can use the Administration Console to restart a server when you add it to a cluster. After adding the machine to the cluster, you must use the Vocera Control Panel to restart it. See [Setting Up an Initial Cluster Configuration](#) on page 79.

To restart a standby node:

1. Display the Vocera Control Panel on the node that you want to restart.
2. Choose **Failover** from the **Cluster** menu of the Vocera Control Panel.
A dialog box asks you to confirm the failover.
3. Click **OK**.
The node restarts without affecting the cluster.

Managing Cluster Nodes

You may want to disconnect a server from a cluster temporarily without permanently breaking up the cluster.

For example, you may want to access the Administration Console of a standby server that you do not have access to when it is part of a cluster, or perform some system maintenance.

Starting a cluster node as a standalone server temporarily removes it from the cluster and allows it to run as an independent Vocera Voice Server. When running standalone, a Vocera Voice Server is no longer part of a cluster and no longer communicates with it.

You can start either the active node or a standby node as a standalone Vocera Voice Server.

Starting a Standalone Server

Following these steps to start a clustered node as a standalone server.

1. Display the Vocera Control Panel on the node that you want to start as a standalone server.

2. Choose **Stop** from the **Run** menu of the Vocera Control Panel.

The status indicator disappears and the Vocera Control Panel displays the message "Exiting server process".



Important: If you execute the **Stop** command on the active node, it *does not* cause a failover, but it *does* cause an interruption in badge service until you start the Vocera Voice Server as a standalone server.

3. Choose **Start Standalone** from the **Cluster** menu of the Vocera Control Panel.

The server disconnects from the cluster and starts as a standalone system. When the server finishes starting, the status indicator displays the *Active* status and a green icon.

The exact result of the **Start Standalone** command depends upon the state of the server at the time that you stopped it:

- If the Vocera Voice Server was *active* and badges were connected to it, the badges reconnect when you start the node as a standalone system.
- If the Vocera Voice Server was in *standby* mode, it restarts as an active standalone server, and it does not interfere with the active node of the cluster in any way.

Rejoining a Standalone Server to a Cluster

When you are finished working with the standalone server, you can restart it to join it to the cluster again.

1. Do either of the following:

- On the **Cluster Setup** page of the **Administration Console**, click **Force Restart**.
- In the **Vocera Control Panel**, choose **Failover** from the **Cluster** menu.

A confirmation dialog box appears.

2. Click **OK**.

The standalone server restarts as a cluster node in the same state—active or standby—it was in prior to becoming a standalone server.

Breaking Up a Cluster

When you remove a standby server from a cluster, it becomes active as a standalone server.

You can remove a standby server from a cluster at any time. You cannot remove the active server unless you first fail over control to another node.

See the *Vocera Voice Server Administration Console Guide* or the **Administration Console** online help for complete information.

Manually Installing the Vocera License File

Follow these steps to manually install the Vocera license file when needed.

In order to use the Vocera Voice Server and the Vocera Report Server, you must obtain an XML license file and copy it into the Vocera Voice Server license directory either by running the Vocera Installation Program or by adding it manually. In previous releases, licenses were distributed as a license key which was typed directly into the Vocera installation program user interface during the installation. This process now requires an XML license file rather than a license key.

When updating the license file in a cluster environment, see [Manually Installing the Vocera License for a Cluster Environment](#) on page 84.

To update the Vocera Voice Server and Vocera Report Server license:

1. Navigate to the `vocera\license` directory located in the Vocera installation folder.
2. Copy and paste the Vocera license XML file into the `vocera\license` directory.
3. Refresh the new or temporary license:
 - a. Open the Vocera Administration Console.
 - b. Click **System** in the navigation bar to display the **System** screen.
 - c. On the **System** screen, click the **License Info** tab to display license information.
 - d. Click the **Refresh License** button.
The new license is applied to the Vocera Voice Server server without requiring a server stop and restart.
4. Conditional: Stop and restart the Vocera Voice Server to apply the new license. For more information, see [Stopping and Restarting the Server](#) on page 92.

Condition: The license can only be refreshed without a Vocera Voice Server restart if the new or temporary license includes an increase in the number of users or IP lines. All other changes to the license requires a restart. This condition applies to all of the nodes in a cluster environment as well.

Manually Installing the Vocera License for a Cluster Environment

Follow these steps to manually install the Vocera Voice Server license file in a cluster when needed.

To install the XML license file on more than one machine:

1. On all standby nodes, follow the steps described in [Manually Installing the Vocera License File](#) on page 84.



Note: Every Vocera Voice Server in a cluster must have the license file copied into a license directory.

2. After the standby nodes have rebooted AND completed a remote restore, follow the procedure to apply and refresh the license on the active server. If the refresh process requires a restart then force a fail-over to a standby node to make it become active.

3. On the remaining standby (formerly active) node, update the license key following the steps above.

Setting Up Users and Groups

After you install Vocera Voice Server software and configure Vocera badges and Vocera or third-party client devices, you must set up profiles for users, groups, and (optionally) sites in the Vocera Voice Server database.

Use the following checklist to complete the configuration of your Vocera Voice Server system:

<input type="checkbox"/>	<p>Collect site data.</p> <p>Each site that you define contains its own users, groups, locations, and address book entries. You can set up all your users and groups in the Global site, then transfer them to individual sites later when you define them. It may be more convenient, however, to define your sites in advance and assign users and groups to their appropriate home sites.</p>
<input type="checkbox"/>	<p>Collect the user name data.</p> <p>Collect official names, spoken names, nicknames, phone numbers, and other information that you need to populate the database.</p>
<input type="checkbox"/>	<p>Collect the group data.</p> <p>Create two separate lists for groups: a list of group names and a list of the members of each group.</p>
<input type="checkbox"/>	<p>Enter the user, group, and group member data into the following spreadsheet templates, then save them in CSV format:</p> <ul style="list-style-type: none">• users-template.xls• groups-template.xls• members-template.xls <p>For more information, see the <i>Vocera Data-Loading Reference</i>.</p>
<input type="checkbox"/>	<p>Use the Vocera Administration Console to load the data from the spreadsheets into Vocera.</p>

Completing the Configuration

This section provides an overview of the configuration tasks.

After you set up users and groups, use a Vocera badge to record name prompts for groups and locations. Perform other system configuration tasks in the Vocera Administration Console. For more information, see the *Vocera Voice Server Administration Console Guide*.

1. Log in to the Administration Console.
The default user ID/password is Administrator/admin.
2. Configure the default permissions that all users will have:
 - If you are supporting multiple sites, assign permissions to the **Everyone Everywhere** group.
 - If you are not supporting multiple sites, assign permissions to the **Everyone** group for the Global site.
3. Assign permissions to the groups you have created.
Users accumulate permissions from every group they belong to. If necessary, you can also use membership in groups to *revoke* specific permissions.

4. Specify global settings for the Vocera system.
5. Define location names and neighbors in either of the following ways:
 - Specify the names directly in the Administration Console.
 - Enter the names in a spreadsheet, then import Vocera data in a CSV file.

The location names you choose should be meaningful to users who use the “Locate” command on the badge.
6. Use a badge and voice commands to assign location names to the access point your badge is currently associated with while you roam.
7. Configure SMTP settings for incoming and outgoing email.
8. Schedule automatic system backups to occur at designated times and days, and a maximum number of backup files to maintain.
9. Record names for sites, groups, and locations:
 - a. Click the **Users** button on the navigation bar.
The Add, Edit, and Delete Users page appears and displays a list of users.
 - b. Press the **Call** button on a badge. When the Genie greets you and asks you to say your first and last name, log in as any user.
 - c. In the Administration Console, click **Sites** in the navigation bar.
The Sites page displays a list of sites.
 - d. Using the list of sites as a reference, record a name prompt for each site with the badge.
 - e. In the Administration Console, click **Groups** in the navigation bar.
The Groups page displays a list of groups.
 - f. Using the list of groups as a reference, record a name prompt for each group with the badge.
For example, press the **Call** button on the badge and say “Record name for *Technical Support*.”
 - g. In the Administration Console, click **Locations** in the navigation bar.
The Locations page displays a list of locations.
 - h. Using the list of locations as a reference, record a name prompt for each location with the badge.
For example, press the **Call** button on the badge and say “Record name for *Front Lobby*.”

Testing the Configuration

After you complete the system configuration, use the badge to test the configuration.

To test the configuration:

1. Log in to the Administration Console.
The default user ID/password is Administrator/admin.
2. Click the **Users** button on the navigation bar.
The Add, Edit, and Delete Users page appears and displays a list of users.
3. Press the **Call** button on a badge. When the Genie greets you and asks you to say your first and last name, log in as any user.
4. Perform the following tasks for each user to check the system’s name recognition:
 - Issue a command from the badge that names that user.
For example, say “Call John Smith.”
 - Issue a command from the badge for each alternative spoken names.
For example, say “Play Messages from Johnny Smith”.
 - Issue a command from the badge that names the user and the department.
For example, say “Call Lin in Tech Support”.
 - Test the identifying phrase, if you have defined one.
For example, say “Call John Smith on the third floor”.

Make a list of the names that the system fails to recognize, or confuses with some other name.

5. Click the **Groups** button on the navigation bar to see the list of groups.
The Add, Edit, and Delete Groups page appears and displays a list of groups.
6. Use the badge to check the system's name recognition for each group, as follows:
 - Test the group name
 - Test the group member name-singular
 - Test the group member name-plural
 - Test the alternative group name

Make a list of the names that the system fails to recognize, or confuses with some other name.

7. If the system failed to identify any user or group names, use the Administration Console to make sure the name is spelled correctly.
 - If the name is not a common English name or seems difficult to pronounce, try adding a phonetic spelling as a variant. For example, you might spell Bauer as "Bower". The variant should be added as an alternate spoken name.
 - If the name is consistently interpreted as another name in the database, it may be that the two names are too close for the recognition engine to differentiate between them reliably. To see if this is the problem, temporarily alter the second name through the Users page of the Administration Console so it does not conflict, and then try the problem name again. If the problem name is now recognized consistently, the names were too close for the speech recognition engine. Otherwise, the system is just having difficulty with your pronunciation of the name.
 - If the names are too close, differentiate them by requiring that one of the users be called by the first name and department, first name and last initial, by a nickname, or an identifying phrase. Communicate any such changes to all users.
 - If the system is having trouble with the pronunciation, and supplying a phonetic spelling as an alternate spoken name does not help, it may mean that a custom dictionary entry is required. Contact Vocera Technical Support (support@vocera.com).
8. If necessary, use the badge to check the system's name recognition for each site. For example, say "Connect to Santa Cruz", then say "Call Maya Shui".

To send messages to users and groups:

1. Log in to the Administration Console.
The default user ID/password is Administrator/admin.
2. Click the **Users** button on the navigation bar.
The Add, Edit, and Delete Users page appears and displays a list of users.
3. Press the **Call** button on a badge. When the Genie greets you and asks you to say your first and last name, log in as any user.
4. Use the badge to send a message to individual users.
For example, say "Send a message to Randy Cochran".
5. Log in as the message recipient and make sure the message was recorded properly.
For example, log in as the recipient and say, "Play messages".
6. Use the badge to send a message to a group.
For example, say "Send a message to Tech Support".
7. Log in as a group member and make sure the message was recorded properly.
For example, log in as a group member and say, "Play messages".

Appendixes

Find additional information about installing and configuring a Vocera Voice system.

- [Using the Vocera Control Panel](#) on page 90
- [Vocera Cluster Upgrade Checklist](#) on page 95
- [IP Port Usage](#) on page 97
- [Engage IP Ports](#) on page 98
- [Changing the IP Address of the Vocera Voice Server](#) on page 103
- [Vocera Localization Suite](#) on page 105
- [Performance Tuning for Large Customers](#) on page 107

Using the Vocera Control Panel

Learn how to use the Vocera system tray icon to display the Vocera Control Panel, which lets you control the Vocera Voice Server.

Vocera System Tray Icon

Learn about the use and function of the Vocera system tray.

When the Vocera Voice Server, Vocera SIP Telephony Gateway, or Vocera Client Gateway server starts running, the Vocera system tray icon appears in the server notification area at the right of the taskbar.



Figure 51: System tray



You can use the Vocera system tray icon to start the Vocera Control Panel for your user session. The Vocera Control Panel displays status messages and lets you control the server.



Note: Windows 2008 R2 systems may require additional configuration to add the Vocera Control Panel system tray options to the notification area.

The Vocera system tray icon changes to display the status of the server:

Table 3: Vocera system tray icons

Icon	Description
	The server is running. You can use the Vocera system tray icon to start the Vocera Control Panel.
	The server is not running. You can use the Vocera system tray icon to start the server.
	The server is processing a stop or start request.

To display the Vocera Control Panel:

- Right-click the Vocera system tray icon  , and select the following command appropriate for your server:
 - Vocera Voice Server = **Vocera Control Panel**
 - Vocera SIP Telephony Gateway = VSTG Control Panel
 - Vocera Client Gateway = VCG Control PanelThe Control Panel window appears on the desktop.



Note: On the Vocera Voice Server, a Command Prompt window called Vocera Launcher Console also appears. It displays status messages as Vocera processes are started and stopped.

To start up the server:

- Right-click the Vocera system tray icon , and select the following command appropriate for your server:
 - Vocera Voice Server = Start Vocera
 - Vocera SIP Telephony Gateway = Start VSTG
 - Vocera Client Gateway = Start VCG
- The Control Panel window appears on the desktop.

Displaying Vocera Control Panel Help

Learn how to display Vocera Control Panel help when using the Vocera User Interface.

The Vocera Control Panel has online help that displays in your browser.

To display Vocera Control Panel help:

- Choose Help > Contents.
The help opens in your browser.

Vocera Control Panel Menus

Learn about the Vocera Control Panel commands and functionality.

Table 4: Control Panel menus



Menu	Command	Description	Servers
Run	Start	Starts the server.	VS, VSTG, VCG
	Stop	Temporarily suspends the server.	
	Shutdown	Shuts down the server.	
Display	Normal	Displays only the most significant system events. This is the default.	VS only
	Detailed	Displays all events.	
	Off	Displays no events.	
Cluster	Start Standalone	Temporarily removes a Vocera Voice Server from a cluster and restarts it as a standalone system.	VS only
	Failover	Fails over to the standby Vocera Voice Server, or restarts the server if it's currently in standby.	
Server	IP Address(es)	Specifies the Vocera Voice Server IP address(es) used by the server.	VSTG, VCG
Help	Contents	Displays online help.	VS, VSTG, VCG
	About	Displays version information.	

Determining the Status of the Server

The Vocera Control Panel provides a status indicator below the menu bar at the top of the screen.

The indicator displays one of the following states to tell you whether the server is available for use:

Table 5: Control Panel status

Status	Description
 Active	The server is running and available for use. A standalone Vocera Voice Server is always active unless you have stopped it. A Vocera Voice Server that is part of a cluster is active when it is the primary machine, unless you have stopped it.
 Standby	The server is running but is not available for use. A Vocera Voice Server that is part of a cluster is in the standby state when it is one of the secondary machines.

Stopping and Restarting the Server

Learn how to start and stop the sever, the conditions under which should, and the affect to the clients.

In certain situations, you may need to stop and restart the server. For example, if you want to update the properties in all your badges at the same time, you must stop the Vocera Voice Server and then restart it.

You may want to restart the server when only a few people are using the system. When the server is stopped, clients are unable to connect and communication is temporarily suspended:



- When the Vocera Voice Server is stopped, users cannot communicate with their badges.
- When the Vocera SIP Telephony Gateway is stopped, users cannot place or receive phone calls.
- When the Vocera Client Gateway is stopped, users cannot communicate with the Vocera Collaboration Suite app or with Vocera Smartphones.

The server stops and starts fairly quickly, so if few people are using the system, there will be very little interruption.



Note: You can also use the Server page of the Maintenance screen in the Administration Console to stop and start the server.

To stop and restart the server:

1. In the Vocera Control Panel, choose Run > Stop, or click .
The Control Panel displays messages indicating that the server has stopped.
2. Choose Run > Start, or click .
The Control Panel displays messages indicating that the server has started.

Controlling the Display of Events

On the Vocera Voice Server, the Vocera Control Panel displays a continuously scrolling list of system events, letting you view the system status at a glance.

You determine the level of detail that the Control Panel displays through settings that you make in the menus. You can specify any of the following settings on the Display menu of the Vocera Control Panel:

- **Normal** displays only the most significant system events in the Control Panel. This is the default.
- **Detailed** displays all events in the Control Panel.
- **Off** displays no events in the Control Panel.

Vocera records all system events in the system log files, regardless of the setting you make for the display of events.

Using the Cluster Menu

Learn the commands that you can use to control your cluster and a description of each.

On a Vocera Voice Server that is part of a cluster, the Vocera Control Panel has a **Cluster** menu that lets you control the cluster. For example, you may want to force a failover when you add a new machine to a cluster, or you may want to start one of the machines as a standalone Vocera Voice Server.

The **Cluster** menu provides the following commands:

Table 6: Cluster menu commands

Command	Description
Start Standalone	<p>Temporarily removes a Vocera Voice Server from a cluster and restarts it as a standalone system. This command <i>does not</i> break up a cluster or cause a failover to occur; instead, it allows you to disconnect a server from a cluster temporarily for maintenance.</p> <p>The exact behavior of this command depends upon the state of the server at the time that you stopped it:</p> <ul style="list-style-type: none"> If the Vocera Voice Server was <i>active</i> and badges were connected to it, the badges reconnect when you start the node as a standalone system. If the Vocera Voice Server was in <i>standby</i> mode, it restarts as an active standalone server, and it does not interfere with the active node of the cluster in any way. <p>The Start Standalone command is available only when the Vocera Voice Server is stopped. See Stopping and Restarting the Server on page 92 for more information about stopping the server.</p> <p>The Cluster Setup page on the System screen in the Administration Console does not get updated when you execute the Start Standalone command. That is, the Enable Cluster checkbox remains selected, all the servers remain in the list, and the status of the servers in the list does not change.</p> <p>When you restart a standalone server, it goes into discovery mode and comes online as a cluster node in the same state—active or standby—it was in prior to becoming a standalone server.</p> <p>You can restart a standalone server with either the Failover command in its Vocera Control Panel or the Force Restart button on the Cluster Setup page of its Administration Console.</p>
Failover	<p>Does one of the following, depending on the status of the Vocera Voice Server:</p> <ul style="list-style-type: none"> If the server was <i>active</i>, this command causes control of the cluster to fail over to one of the standby machines. If the server was in <i>standby</i> mode, this command restarts the server, but does not cause control of the cluster to fail over. If the server was running as a standalone server, this command restarts the server as a cluster node in the same state—active or standby—it was in prior to becoming a standalone server.

If failover occurs in a clustered environment, the control panel opens to the active server instance.

Changing the Vocera Voice Server IP Address

Follow these steps to change the Vocera Voice Server IP address.

The Vocera SIP Telephony Gateway, and Vocera Client Gateway need to know the IP address(es) of the Vocera Voice Server. You enter this IP address(es) when you install the software. However, you can use the Vocera Control panel to change the address.

To change the Vocera Voice Server IP address used by the server:

- In the Vocera Control Panel, choose **Server > IP Address(es)**.
The IP Address dialog box appears.
- Use the **Server IP Address** field to provide the address of the Vocera Voice Server.

Enter the numeric IP address using dot notation. For example:

192.168.15.10

For a Vocera Voice Server cluster, enter a comma-separated list of IP addresses. For example:

192.168.15.10,192.168.15.11,192.168.15.12

3. Click **OK**.

The dialog box closes, and the server begins using the new Vocera Voice Server IP address immediately.

Shutting Down the Vocera Voice Server

Follow these steps to stop the Vocera Voice Server.

When you shut down the server, you stop the Vocera Voice Server and all its related services. In the case of the Vocera Voice Server, this includes MySQL, Tomcat, Apache Web Server, and Nuance.

To shut down the server:

1. In the Vocera Control Panel, choose **Run > Shutdown**.

A confirmation dialog box appears.

2. Click **OK**.

The dialog box closes, and the Control Panel also closes.

If you shut down the Vocera Voice Server, the launcher Command Prompt window displays messages indicating that Vocera and its related services are stopping. When all Vocera services have stopped, the Command Prompt window closes.

Vocera Cluster Upgrade Checklist

This section provides a high-level checklist for upgrading from your current Vocera Voice Server cluster to a Vocera 5.2.3 cluster.

For more details on the upgrade steps in this checklist, see [Upgrade Consideration for a Cluster: Planned Downtime](#) on page 23.

If you are upgrading with new machines, see [Active and Inactive Node Order](#) on page 23.

Table 7: Cluster Upgrade Checklist

<input type="checkbox"/>	Make sure your hardware and operating system are capable of supporting Vocera 5.2.3. See the Vocera Voice Server Sizing Matrix .
<input type="checkbox"/>	Confirm that the Vocera Voice Server is set up properly. See Preparing the Vocera Voice Server on page 39.
<input type="checkbox"/>	Back up your Vocera Voice Server data. See Backing up Vocera Data on page 30.
<input type="checkbox"/>	If your current Vocera Voice Server installation has customized properties files, back up the files to a flash drive or to a temporary location on a network drive. After you install Vocera 5.2.3, you will need to merge the changes into the corresponding file on your upgraded servers. See Upgrading Properties Files on page 29.
<input type="checkbox"/>	If Vocera Report Server is running, shut it down.
<input type="checkbox"/>	Make sure Vocera badges are configured with the correct comma-separated list of IP addresses in the <i>Vocera Server IP Address</i> property. If necessary, use the Badge Properties Editor to update the <i>badge.properties</i> file on every cluster node. For details, see the <i>Vocera Device Configuration Guide</i> .
<input type="checkbox"/>	Shut down the standby Vocera Voice Server to make it inactive. If there are multiple standby Vocera Voice Servers, shut down ALL of them.
<input type="checkbox"/>	Upgrade the Vocera Voice Server on one of the inactive nodes.  Note: If your current Vocera installation had a modified <i>Properties.txt</i> file, merge the changes into the corresponding file on your new server.
<input type="checkbox"/>	Shut down the following: <ul style="list-style-type: none"> Vocera Client Gateway Vocera SIP Telephony Gateway
<input type="checkbox"/>	Shut down the <i>active</i> node of the Vocera Voice Server cluster. Make sure a Vocera Voice Server node that has been updated to version 5.2.3 is now active.
<input type="checkbox"/>	Upgrade Vocera SIP Telephony Gateway and Vocera Client Gateway to version 5.2.3, as appropriate. <ul style="list-style-type: none"> Upgrading Vocera SIP Telephony Gateway on page 31 Upgrading Vocera Client Gateway on page 32

<input type="checkbox"/>	Update other standby nodes to version 5.2.3.  Note: If your current Vocera installation had a modified <code>Properties.txt</code> file, merge the changes into the corresponding file on your new server.
<input type="checkbox"/>	Update Client devices and the Vocera Badge with the latest firmware. See the Vocera Device Configuration Guide, Vocera Collaboration Suite Apple iOS User Guide, and Vocera Collaboration Suite Android User Guide.
<input type="checkbox"/>	Upgrade Vocera Report Server as appropriate. See Upgrading Vocera Report Server on page 32.
<input type="checkbox"/>	Upgrade Vocera Administration Interface (VAI) applications as appropriate. See Upgrading Vocera Administration Interface Applications on page 33.
<input type="checkbox"/>	Perform the post-installation tasks to completely migrate your data to Vocera 5.2.3: <ul style="list-style-type: none">• See Changes in Behavior on page 35• See Suggested Post-Upgrade Tasks on page 37.



IP Port Usage

This section list the ports that must be opened on the Voice Server and Engage Linux 5.x machine, so that the client and server can communicate with each other.

Engage IP Ports

The port numbers that must be opened on the Engage Linux 5.x machine for effective communication are listed in this topic.

Port Number	Protocol	Source	Destination	Interface/ Feature	Purpose
443	TCP	Engage Middleware Module	svc.ext-inc.com 199.180.201.227		Provisioning APNS certificate retrieval
22	TCP	Engage Middleware Module	svc.ext-inc.com 199.180.201.227		Remote Support
443	TCP	Engage Middleware Module	yum.ext- inc.com 199.180.201.238		Repository access for installing Ubuntu and Engage Middleware Module software updates
2196	TCP	Engage Middleware Module	feedback.push.ap 17.0.0.0/8	XMPP	Retrieve list of failed devices from Apple Push Notification Service (APNS) Outbound, to Apple
5223	TCP	Engage Mobile App, iOS device	*.push.apple.com 17.0.0.0/8	XMPP	Receive push notifications on Engage Mobile App, iOS device . According to Apple, the iOS device is using Wi-Fi, port 5223 must be open outbound and inbound to the Wi-Fi. If all devices are using 4G port 5223 is not required.

Port Number	Protocol	Source	Destination	Interface/ Feature	Purpose
443	TCP	Engage Mobile	Engage Mobile		Workflow page access for Android and Engage Mobile App, iOS devices using a reverse proxy in a DMZ. Traffic from any address to Engage Middleware Module on port 443 must be open unless a reverse proxy is used.
443	TCP	Engage Middleware Module (all networks)	Reverse proxy		Workflow page access for Android and Engage Mobile App, iOS devices using a reverse proxy in a DMZ. Traffic from any address to the proxy on port 443 must be open. Using a reverse proxy also has an internal requirement for the proxy to access Engage Middleware Module.
443	TCP	External browser access (all networks)	Engage Middleware Module		When workflow page access for browsers outside the network is desired not using a reverse proxy. Traffic from any address to Engage Middleware Module on port 443 must be open unless a reverse proxy is used.

Port Number	Protocol	Source	Destination	Interface/ Feature	Purpose
443	TCP	External browser access (all networks)	Reverse proxy		When workflow page access for browsers outside the network is desired not using a reverse proxy. Traffic from any address to Engage Middleware Module on port 443 must be open unless a reverse proxy is used.
5222	TCP	Engage Mobile iOS	Engage Middleware Module	XMPP	Client to server XMPP traffic use the well known port 5222.
5222	TCP	Engage Mobile iOS	Edge> Engage Middleware Module	XMPP	External XMPP traffic communicates with Engage Middleware Module through the Edge XMPP proxy on port 5222.
5269	TCP	Federated XMPP Server	Engage Middleware Module	XMPP	Federated server communication uses port 5269. Federation can be initiated in either direction. This does not need to be opened externally if only federating with servers on the internal network.
5269	TCP	Engage Middleware Module	Federated XMPP Server	XMPP	Federated server communication uses port 5269. Federation can be initiated in either direction. This does not need to be opened externally if only federating with servers on the internal network.

The following tables indicates the internal network requirements

Port	Protocol	Source	Destination	Interface/ feature	Purpose
443	TCP	Reverse proxy	Engage Middleware Module		Reverse proxy access to Engage Middleware Module when a proxy is used in a DMZ for external smart phone or external browsers.
22	TCP	Any SSH client	Engage Middleware Module		SSH access.
80	TCP	Any HTTP client	Engage Middleware Module		Admin Console and workflow access via HTTP.
80	TCP	Cisco Phones SpectraLink Phones	Engage Middleware Module		Workflow access from mobile devices.
443	TCP	Any HTTP client	Engage Middleware Module		Admin Console and workflow access via HTTPS.
8888	TCP	Any HTTP client	Engage Middleware Module	Mirth	HTTP access to Mirth client download and login.
8443	TCP	Mirth Client	Engage Middleware Module	Mirth	Mirth administration once client is downloaded.
389	TCP	Engage Middleware Module	LDAP Server	LDAP	LDAP default configuration for Active Directory.
2021	TCP	Engage Middleware Module	DigiBox	TAP / Serial Devices	Default non-secure DigiBox port.
1322	TCP	Engage Middleware Module	Unite Connectivity Manager (UCM)	Ascom	Push interactive messages to Ascom devices.
5000 - 5004	TCP	UCM	Engage Middleware Module	Ascom	UCM responses to message delivery.
27015	TCP	Engage Middleware Module	Vocera Server	Vocera	Communicate with Vocera server.
25	TCP	SMTP Client	Engage Middleware Module	Incoming e-mail	Inbound SMTP messages for the incoming e-mail interface.
25	TCP	Engage Middleware Module	SMTP	Outgoing e-mail	Outbound SMTP messages from the outgoing e-mail interface.

Port	Protocol	Source	Destination	Interface/ feature	Purpose
6661	TCP	HL7 (LLP)	Engage Middleware Module	HL7	Inbound HL7 messages. This is the default port configured in Mirth. This might be changed or additional connections added. Any additional connections require opening the ports.
12000	TCP	Navicare Server	Engage Middleware Module	Navicare	Inbound Hill- Rom Navicare messages
2000	UDP	Carescape Network	Engage Middleware Module	Carescape	Time synchronization.
7000	UDP	Carescape Network	Engage Middleware Module	Carescape	Device discovery
7000	UDP	Carescape Network	Engage Middleware Module	Carescape	Alarm Messages
161	UDP	SNMP Client	Engage Middleware Module	SNMP	Query Engage Middleware Module for SNMP parameters.
161	UDP	Engage Middleware Module	SNMP Manager	SNMP	Send SNMP traps for audit events.

The following tables indicates the inbound Engage Middleware Module ports.

Port	Protocol	Purpose
22	TCP	SSH access
80	TCP	HTTP access
443	TCP	HTTP access
6661	TCP	Default HL7 port
8443	TCP	Mirth HTTPS administrative access
8888	TCP	Mirth HTTP client access
161	TCP	SNMP



Changing the IP Address of the Vocera Voice Server

Learn how to change the IP address of the Vocera Voice Server.

Introducing the Change Server IP Address Utility

Vocera provides a simple utility called Change Server IP Address that updates the Vocera Voice Server IP address in all the locations used by the Vocera software.

After you install the Vocera software, you may decide to change the IP address of the Vocera Voice Server. The Change Server IP Address utility is located in the `\vocera\tools` directory on the Vocera Voice Server, but you can also run it from the Windows **Start** menu.

Supported Vocera Environments

Learn about Change Server IP Address utility and when you can use it.

The Change Server IP Address utility works in the following environments:

- A stand-alone Vocera Voice Server (Vocera Voice Server that is not part of a cluster)
 - A server where both Vocera Voice Server and Vocera SIP Telephony Gateway Server are installed
 - A Vocera Voice Server that is part of a cluster
-

Using the Change Server IP Address Utility

Following these steps to update the IP address used by the Vocera Voice Server software.

1. Log in to the Vocera Voice Server computer with administrator privileges.
2. Shut down the Vocera Voice Server. In the Vocera Control Panel, choose **Run > Exit**. Click **OK** to confirm.
3. From the Windows **Start** menu, select **Settings > Control Panel > Administrative Tools > Services**. The Services window appears, displaying the list of installed Windows services.
4. Confirm that all Vocera services have shut down. This includes Vocera Launcher, MySQL, Apache2, Tomcat, and the Nuance Watcher Daemon. If any one of these services is running, right-click it and choose **Stop**.
5. Choose **Start > Programs > Vocera > Change Server IP Address**.
6. Specify the old IP address used by the Vocera Voice Server and the new IP address. By default, the old IP address is the value of the `VOCERA_LOCAL_HOST_ADDRESS` environment variable and the new IP address is the current NIC address of the server.
7. Click **Change IP**.
The utility proceeds to update the server.
8. Select **Yes, I want to restart my computer now**, and then click **Finish**.

After the server restarts, the Vocera Voice Server launches and displays the Vocera Control Panel.



Note: All changes made by the Change Server IP Address utility are saved to a log file named `IPAddressChange.log` in the `InstallLogs-Vocera` directory.



Vocera Localization Suite

This section provides information related to the Vocera Localization Suite.

Vocera provides users the ability to customize the Vocera Voice Server and the Vocera Report Server for different locales. When you install the Vocera Localization Suite, speech recognition behavior, genie prompts, and the telephony dial-plan are modified to reflect the locale conventions.

For more information on installing localization suites, see the localization release notes for the locale and version that you want to install.

Dialing Plan

Learn about how locales affects the dial plan when your environment includes telephony integration.

In a Vocera Voice Server installation that includes the telephony integration, the locale determines the dialing plan, which specifies how phone numbers are formatted and interpreted.

For example, the dialing plan for the United States (US) locale assumes that phone numbers longer than 10 digits contain complete information. Given an 11-digit number, Vocera would dial it as-is, without adding access codes or area codes.

That same number would be handled differently by a Vocera system configured for the United Kingdom (GB) locale. The corresponding dialing plan supports home and business phone numbers up to 11 digits in length, so Vocera would add access codes or area codes, as appropriate, before dialing.

Genie Personas

Learn how the Genie's persona changes when you select a local.

The Vocera system locale determines which Genie personas are available in the Administration Console and the User Console. For example, when Vocera is configured for the United States (US) locale, the Genie personas Dan and Jennifer are available. When Vocera is configured for the United Kingdom (GB) locale, the Genie personas George and Emma are available. The Genies for each locale use the appropriate language and accent for prompts and responses.

You can choose a Genie persona (and specify whether users can override this choice) from the Genie Settings page of the Defaults screen in the Administration Console. Users can choose a Genie persona from the Genie Settings page of the Announcements screen in the User Console (if granted access by an administrator).

Grammars

Learn about locals and the associated grammars.

Each locale has an associated grammar directory (under `\vocera\server\grammars`) that stores the system grammars (mainmenu, phonenumber, etc.) for that locale. Different locales can share the same localization pack but have different grammars. The AU and NZ locales are an example. For this reason, the grammar directories have locale names rather than package names. Directories for all supported grammars are created on the server computer when you install Vocera.

Localization Packs

Learn how the selected locale affects speech recognition, text-to-speech, and the Vocera genie.

Vocera uses localization packs for speech recognition and text-to-speech actions. The following table lists supported locales and corresponding localization suite.

Locale	Speech Recognition	Text-to-Speech	Genies
United States (US)	English US	English US	Jennifer, Dan
Singapore (SG)	English SG	English US	Jennifer, Dan
United Kingdom (UK)	English UK	English UK	George, Emma
Australia (AU)	English AUS/NZ	English UK	George, Emma
New Zealand (NZ)	English AUS/NZ	English UK	George, Emma
Canada (CA)	English US	English US	Jennifer, Dan
Landstuhl (Germany)	English US	English US	Jennifer, Dan
Malaysia	English SG	English US	Jennifer, Dan
United Arab Emirates (UAE)	English US	English US	Jennifer, Dan
Kingdom Saudi Arabia (KSA)	English US	English US	Jennifer, Dan
Qatar	English US	English US	Jennifer, Dan
Oman	English US	English US	Jennifer, Dan

The binary representation of a learned command in Vocera database tables depends on the localization suite (and therefore the acoustic model) in use when the name or command is learned. When the Vocera system learns a name or keyword, it notes which localization suite is in use. Vocera keeps a separate set of learned names and keywords for each localization suite.

Performance Tuning for Large Customers

This appendix provides performance tuning recommendations for large customers.

A large Vocera system typically has more than 2,500 users at multiple sites and a spoken name count (which includes user names, group names, alternate spoken names, and department names) equal to or greater than 90,000.

Installation Prerequisites and Recommendations

Learn the tasks and suggested steps you can implement in your large system.

General Recommendations

- Set the cluster size for the Vocera drive to 64 KB.
For more information, see the following articles:
 - [How to Locate and Correct Disk Space Problems on NTFS Volumes](#) .
 - [Recommendations and Guidelines on configuring disk partitions for SQL Server](#).
- Change from RAID 5 to RAID 10.
Vocera is both read and write intensive. As a result, choose a RAID option that optimizes both read and write, such as RAID 1+0.
For more information, see [Performance Tuning Guidelines for Windows Server 2012 R2](#).
- Make sure the %VOCERA_DRIVE% is located on a different physical disk than the system and pagefile drive.
- Configure your server to set processor scheduling and memory usage to Programs.
For more information, see [Configuring Performance Options](#) on page 40.
- If you are running anti-virus software on the Vocera Voice Server, set up folder exclusions for the %VOCERA_DRIVE%\vocera directory.
For more information, see [KB737](#) in the Vocera Technical Support Knowledge Base.
- Check server specifications against the Vocera Voice Server Sizing Guide.
- Improve performance by defragmenting your hard disks. Perform this task regularly to maintain disk performance.
For more information, see [Defragmenting SQL Server database disk drives](#).

Post-Installation Recommendations

Learn the tasks you can perform after installation.

- Increase the number of log files retained by the Vocera Voice Server to 150 or 200 files.
By default, the Vocera Voice Server retains up to 100 log files. You can increase this number by modifying the LogMaxFiles property in the \vocera\server\Properties.txt file on the Vocera Voice Server:

```
LogMaxFiles      =      200
```



Note: If you modify the `Properties.txt` file, you must stop and start the Vocera Voice Server to load the properties into memory.

- Remove inactive Vocera users, groups, and address book entries.
You can use the Vocera Report Server to generate reports of inactive Vocera users, groups, and address book entries. Once you identify inactive Vocera entities, you can delete them in the Vocera Voice Server Administration Console.

Configuring Performance Options

Nuance Speech Recognition, Verifier, and Vocalizer software works best when the server is set to give the best performance to programs rather than background services.

In programs mode, the Windows operating system provides more frequent but smaller time slices during thread switching. In background services mode, the Windows operating system provides longer and less frequent time slices. Therefore, if you run Windows with background services mode, Vocera badges may experience choppy audio.

To set Windows performance options for the Vocera Voice Server, perform the following steps:

1. Choose Start >Settings >>Control Panel>System.
The System Properties dialog box appears.
2. Click **Advanced**.
3. Under **Performance**, click **Settings**.
The Performance Options dialog box appears.
4. Click the **Advanced** tab.
5. In the **Processor Scheduling** box, click **Programs**.
Making this selection provides more processor resources to the Vocera Voice Server instead of resources going to background services.
6. Under **Memory Usage**, click **Programs**.
Making this selection provides more system memory to the Vocera Voice Server instead of the system cache.
7. Click **OK**.
A dialog box with the information to restart the computer for the changes to take effect is displayed.
8. Click **OK**.
The dialog box is closed.
9. In the **Performance** box, click **OK**.
10. In the **System Properties** box, click **OK**.
11. Restart the computer.